

PB15

Sistema scorrevole per ante rientranti

Sliding system for pocket doors

Système coulissant pour portes escamotables

Drehschiebetürbeschlag für Möbelschranke

Sistema corredero para puertas escamoteables

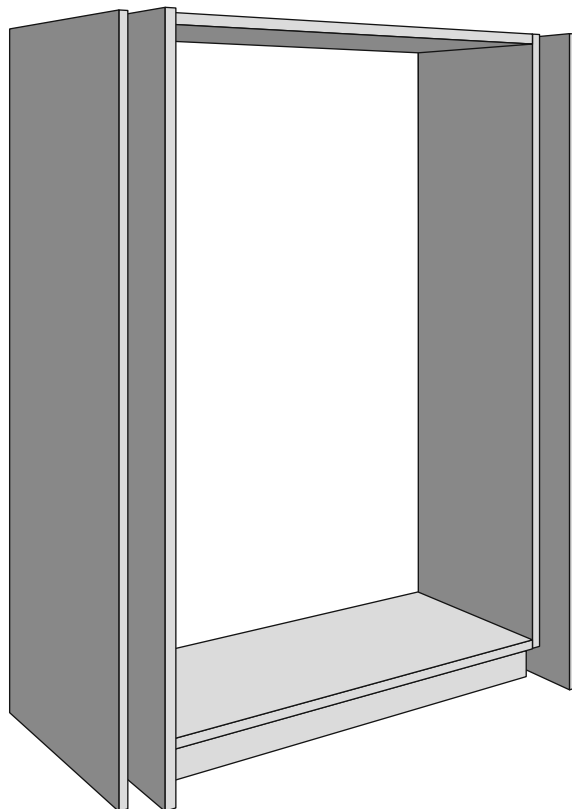
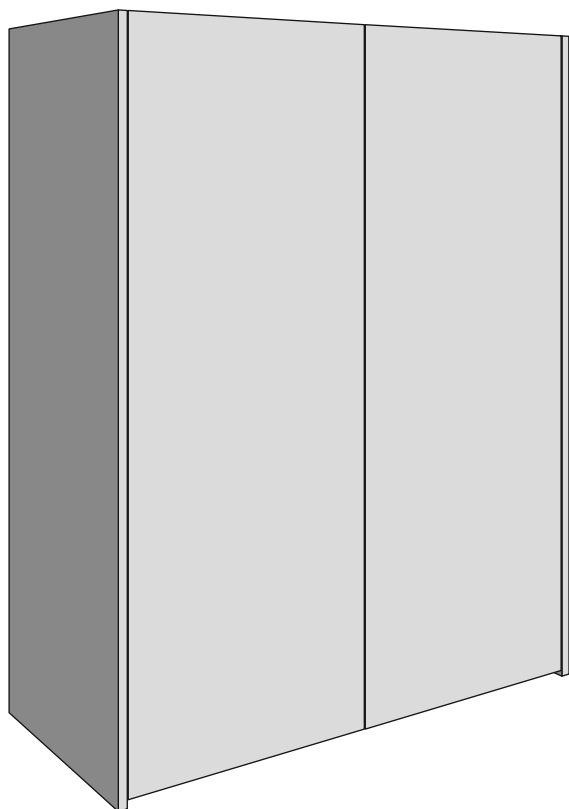

MANUALE TECNICO

TECHNICAL HANDBOOK

MANUEL TECHNIQUE

TECHNISCHES HANDBUCH

MANUAL TÉCNICO





QUESTO MANUALE TECNICO SI RIFERISCE ALLA REALIZZAZIONE DI ANTE SCORREVOLI RIENTRANTI PB15 I CUI MECCANISMI RIPORTANO I SEGUENTI CODICI: PB15KT70000021, PB15KT70000022, PB15KT70000023, PB15KT70000024, PB15KT70000025, PB15KT70000026, PB15KT70000027, PB15KT70000028, PB15KT70000029, PB15KT70000030, PB15KT70000031, PB15KT70000032.

THIS TECHNICAL HANDBOOK REFERS TO THE MANUFACTURE OF PB15 RETRACTING SLIDING DOORS WHOSE MECHANISMS BEAR THE FOLLOWING CODES: PB15KT70000021, PB15KT70000022, PB15KT70000023, PB15KT70000024, PB15KT70000025, PB15KT70000026, PB15KT70000027, PB15KT70000028, PB15KT70000029, PB15KT70000030, PB15KT70000031, PB15KT70000032.

Italiano

Tutte le misure espresse in questo opuscolo sono in millimetri.

ATTENZIONE

Non utilizzare spray ed oli anti frizione o sblocca filetti sui cuscinetti o sulle ruote con O-ring dei pattini scorrevoli. Questo provoca lo scioglimento dei grassi dei cuscinetti rendendoli rumorosi oppure la rottura dell'O-ring.

Le illustrazioni e le descrizioni di questo opuscolo si intendono fornite a titolo indicativo. L'azienda si riserva pertanto di apportare, in qualsiasi momento e senza preavviso, quelle modifiche che ritenesse utili per qualsiasi esigenza di carattere costruttivo e commerciale.

Deutsch

Alle Maße in diesem Katalog sind in Millimetern.

ACHTUNG

Kein Spray, Schmiermittel oder Lösenmittel auf die Kugellager und Rollen mit O-Ring der Laufwagen verwenden. Das kann die Kugellager und die Rollen geräuschvoller machen und kann den O-Ring Abriss verursachen.

Die Bilder und Beschreibungen dieses Prospektes sind nur zur Information gegeben. Die Firma kann, in jedem Moment, Änderungen und Verbesserungen ohne Vorankündigung vornehmen.

English

All dimensions in this leaflet are stated in millimeters.

WARNING

Do not use any anti-friction oil or grease or thread-release spray on ball bearing or on wheels with O-ring, it can cause the melting of the inside ball bearing grease, making them noisy or causing the break of the O-ring of the wheels.

The pictures and descriptions this leaflet contains are supplied for information purposes. The company reserves the right to introduce those modifications it deems opportune for any construction or commercial need at any time and without advance notice.

Español

Todas las dimensiones en este folleto se expresan en milímetros.

ADVERTENCIA

No utilices spray y aceites anti-fricción sobre los cojinetes de bolas y sobre las ruedas con O-ring de los patines. Esto puede provocar mayor rumorosidad de los cojines o la rotura de los O-ring.

Las imágenes y las descripciones de este folleto solo se fechan a título informativo. La empresa puede aportar, en cualquier momento y sin preaviso, las modificaciones que cree necesarias por exigencias técnicas y comerciales.

Français

Toutes les mesures indiquées dans cette brochure sont en millimètres.

AVERTISSEMENT

Ne pas utiliser de spray ni d'huile anti frottement ou pour débloquer les filets sur les coussinets ou sur les roulettes avec bague torique des patins coulissants. Ce qui ferait fondre la graisse des roulements en les rendant bruyants ou provoquerait la rupture de la bague torique.

Les images et les descriptions de cette notice ne sont fournies qu'à titre indicatif. Le fabricant se réserve donc le droit d'apporter toutes les modifications qu'il jugera utiles à des fins techniques et commerciales à n'importe quel moment et sans aucun préavis.

Informazioni sul prodotto.

Product information.

Informations sur le produit.

Produktinformation.

Información sobre el producto.

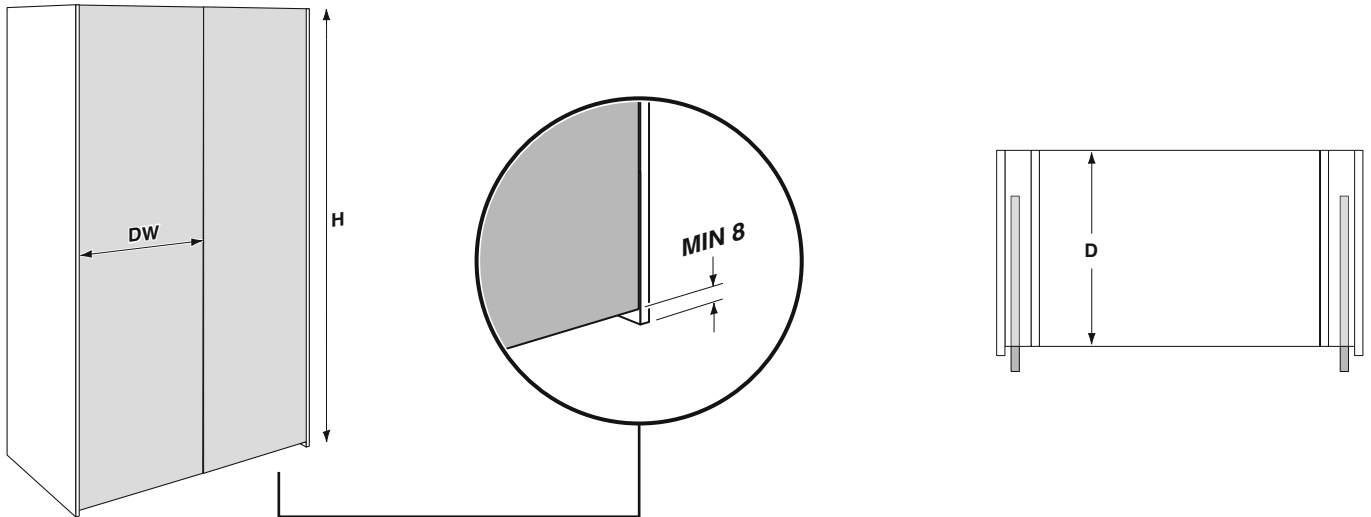

SPECIFICHE TECNICHE DELL'ANTA

DOOR TECHNICAL DATA.



Si raccomanda di usare una guarnitura raddrizza-ante per la stabilizzazione di ante scorrevoli.

It is recommended to use the straightening fitting for stabilizing sliding doors.

Pour stabiliser les portes coulissantes il est recommandé d'utiliser une ferrure du raidisseur de porte.

Ausrichtbeschlag zur Stabilisierung von Schiebetüren verwenden.

Para estabilizar las puertas correderas se recomienda utilizar un herraje de alineación.

PB15 è compatibile con cerniere standard, ammortizzate, di diversi marchi facilmente reperibili sul mercato.

Caratteristiche della cerniera:

- collo 0
- angolo di apertura $84^{\circ} \div 96^{\circ}$
- sormonto, a discrezione del cliente

PB15 is compatible with standard, soft-closing hinges of different brands that are easily available on the market.

Features of the hinge:

- neck 0
- opening angle $84^{\circ} \div 96^{\circ}$
- overlap, at customer's request

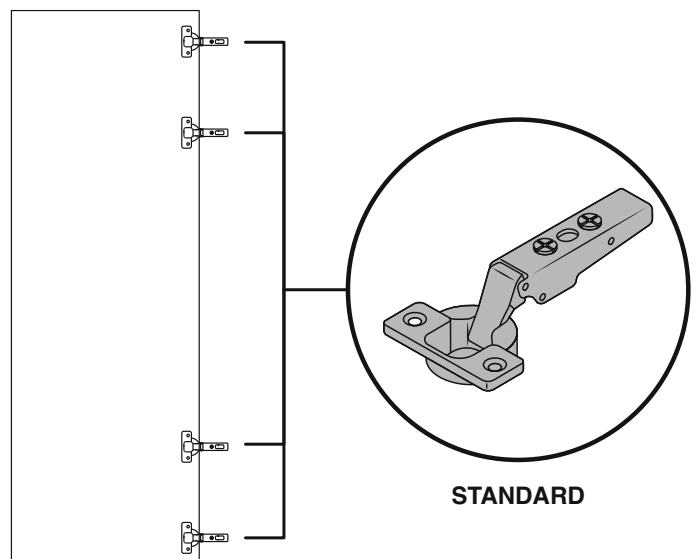

ABBREVIAZIONI:

- D** = profondità del fianco
- D1** = profondità del pannello di tamponamento
- FD** = profondità meccanismo
- H** = altezza del pannello di tamponamento
- H1** = altezza anta
- H2** = altezza fianco
- DW** = larghezza anta
- T** = spessore anta
- G** = mancato rientro
- O** = mancato sormonto sul cappello

ABBREVIATIONS:

- D** = side panel depth
- D1** = cover panel depth
- FD** = fitting depth
- H** = cover panel height
- H1** = door height
- H2** = side height
- DW** = door width
- T** = door thickness
- G** = missing entrance
- O** = portion of the top panel, not overlapped by the door

	1600÷2000	R - L
H1	2001÷2400	R - L
	2401÷2800	R - L
DW	400÷700	
D	≥550	
FD	550÷750	if $D \leq 750$, $FD = D$
		if $D > 750$, $FD = 750$
G	$(DW - FD) + 188,5$	

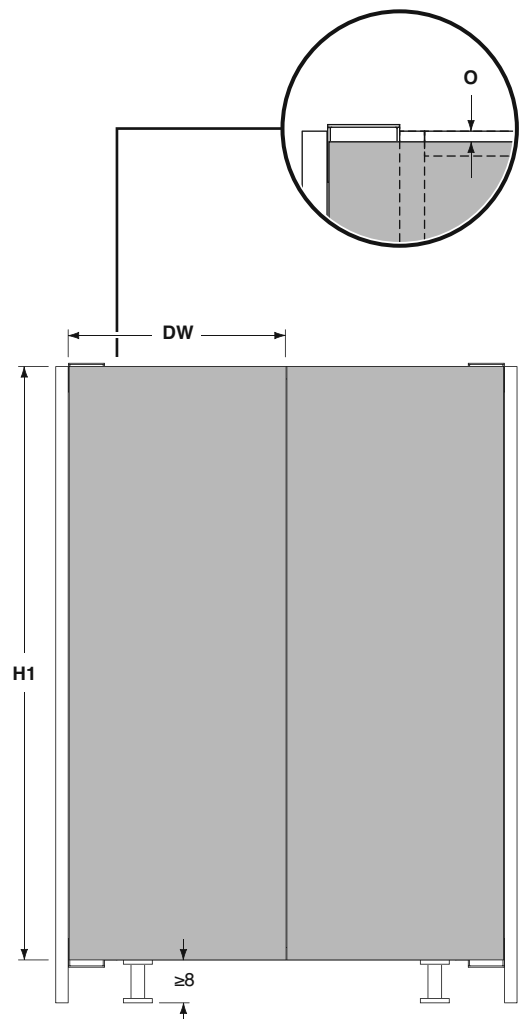
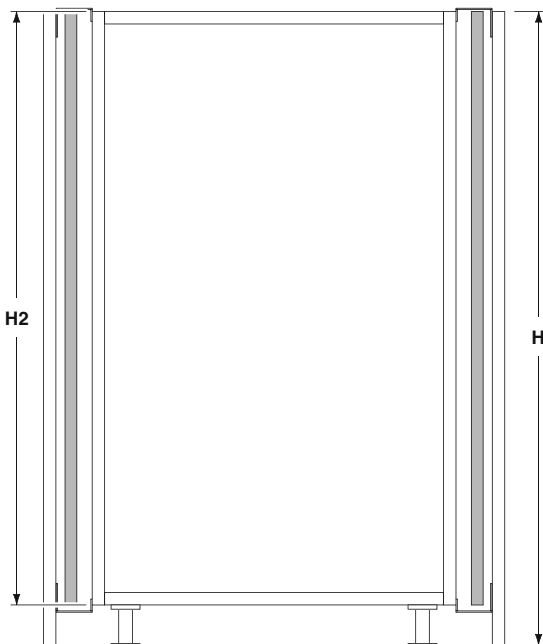
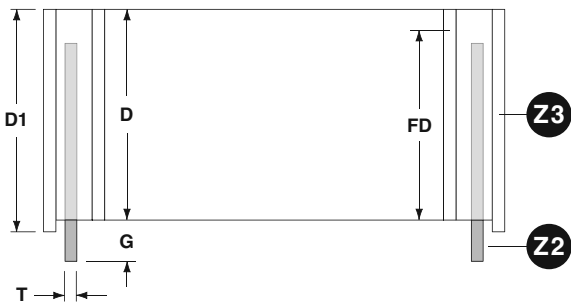
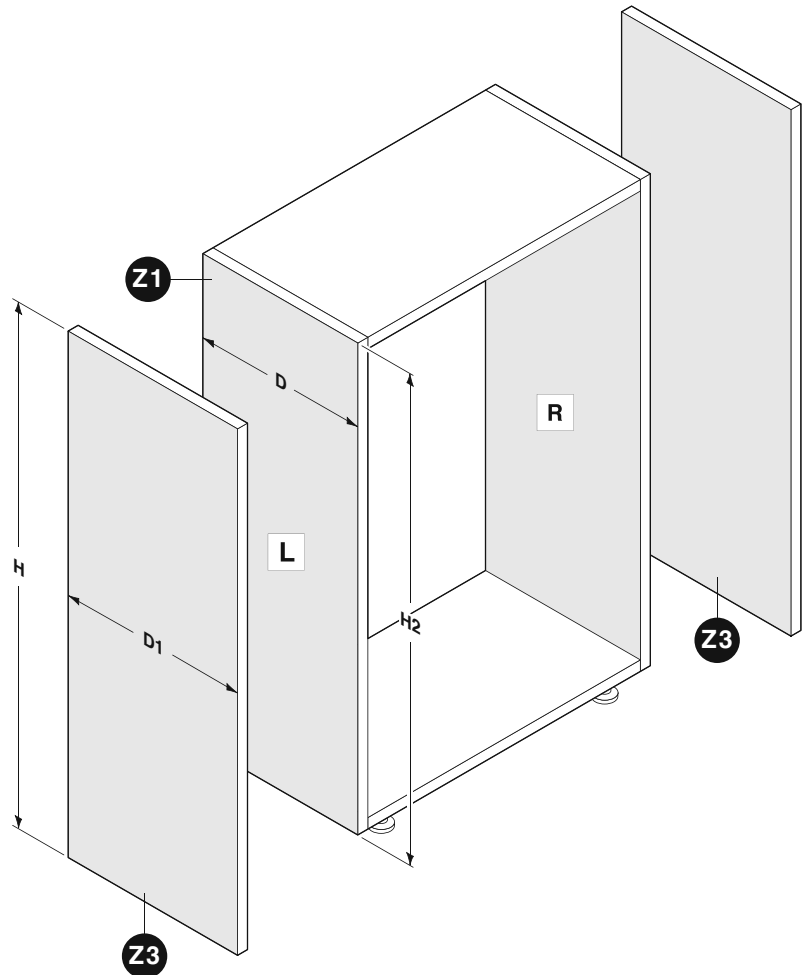











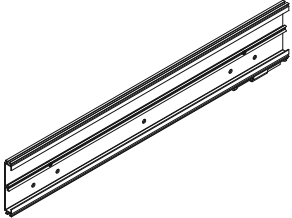

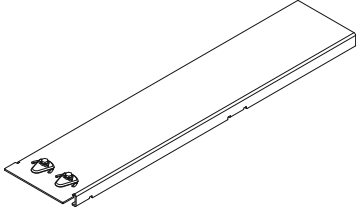
Panoramica dei componenti.

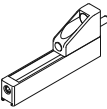
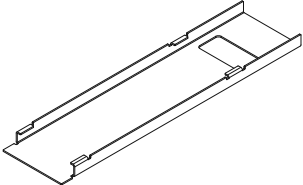
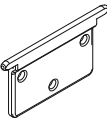
Parts list overview.

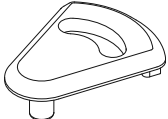
Aperçu général des composants.

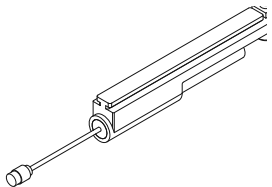
Übersicht der Bestandteile.

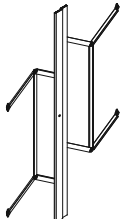
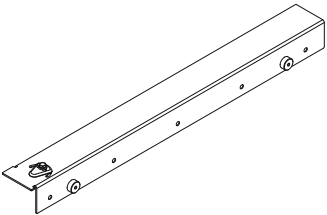
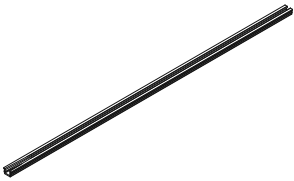
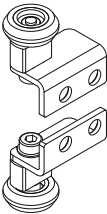
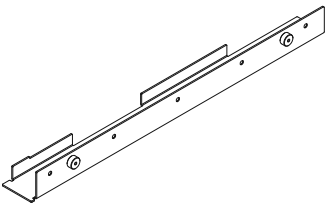
Esquema de componentes.

<p>1 GGBN70020004 (L) / 05 (R)</p> 	<p>7 VL60100611</p> 	<p>13 GGAC1VN60005</p> 
<p>2 GGBN70020006 (L) / 13 (R)</p> 	<p>8 GGAC81200002</p> 	<p>14 LT123VN6200008</p> 
<p>3 TE865160000305</p> 	<p>9 TR8780822022</p> 	<p>15 TE868160000304</p> 
<p>4 TE865160000303</p> 	<p>10 GGAC81200001</p> 	<p>16 VM85100506</p> 
<p>5 *** (page 6)</p> 	<p>11 GGAC1VN60017 (R) / 19 (L)</p> 	<p>17 SP7BN9020001</p> 
<p>6 CN01000482</p> 	<p>12 GGAC1VN60018 (R) / 20 (L)</p> 	<p>18 TE884200000309</p> 

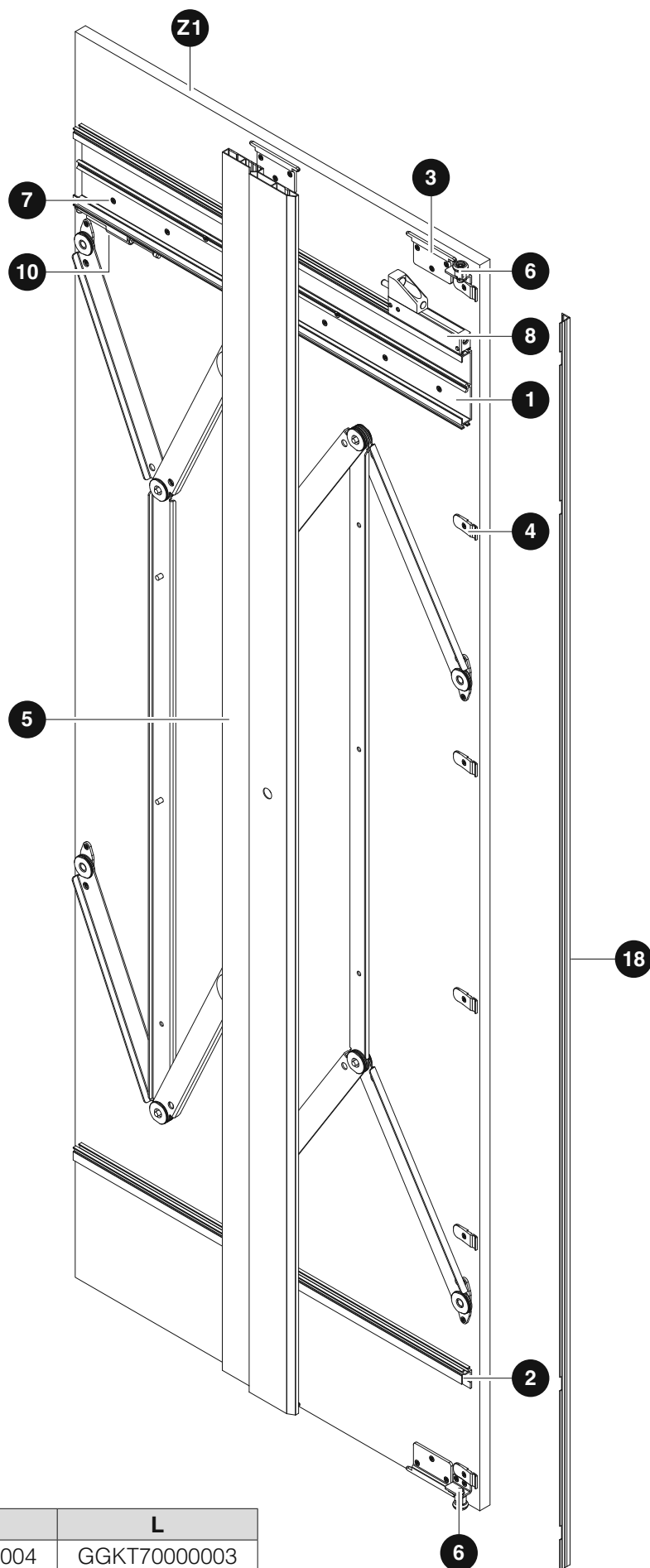
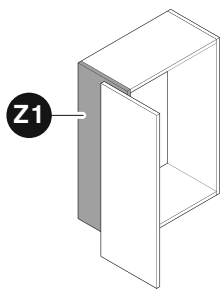

5 ***

H1	R	L
1600÷2000	GGKT70000004	GGKT70000003
2001÷2400	GGKT70000002	GGKT70000001
2401÷2800	GGKT70000006	GGKT70000005

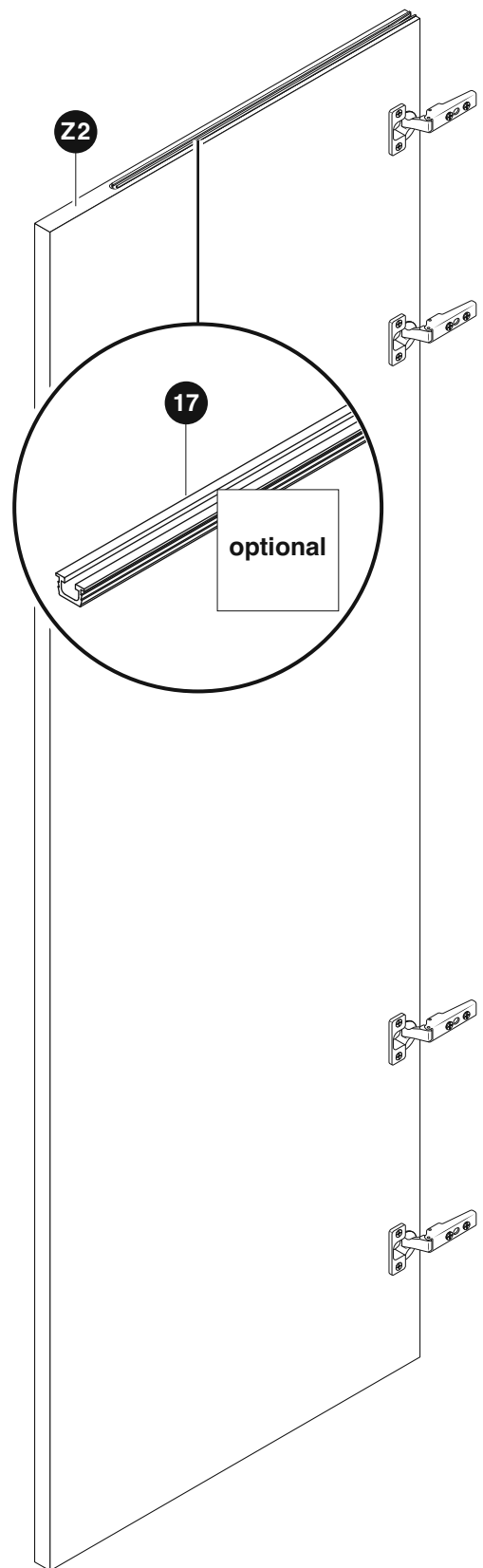
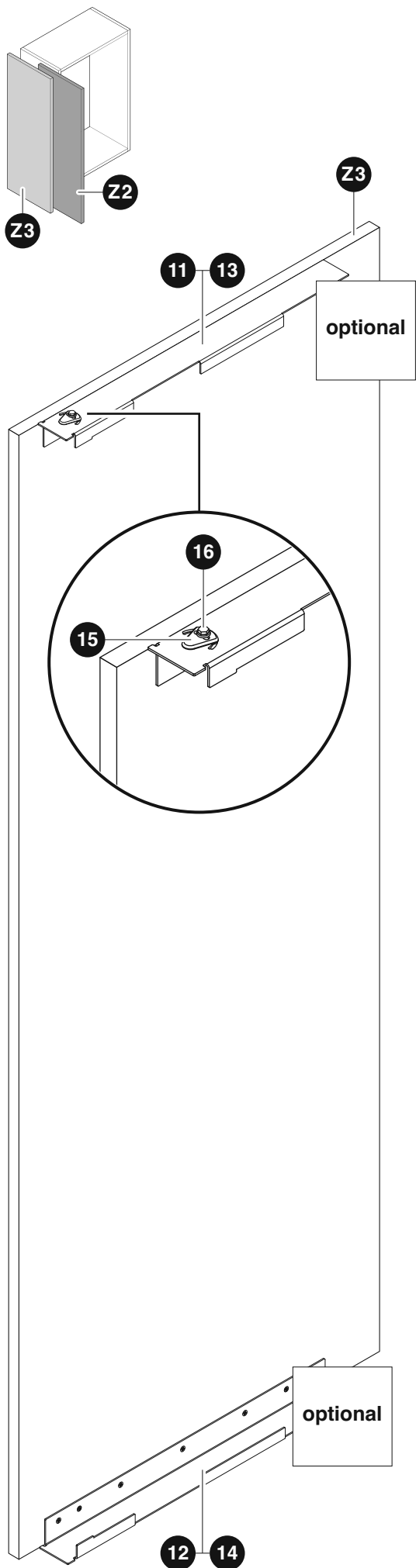

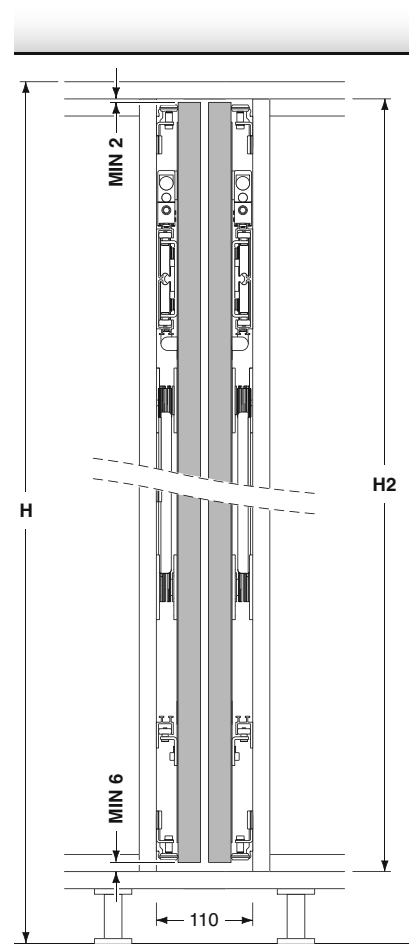
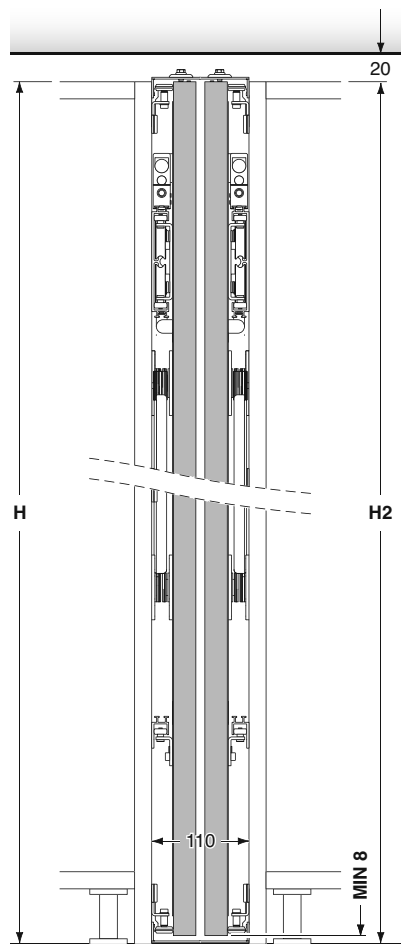
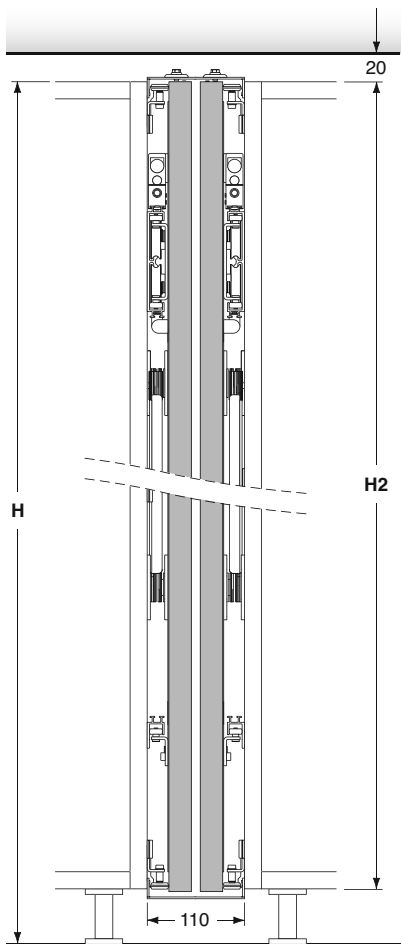
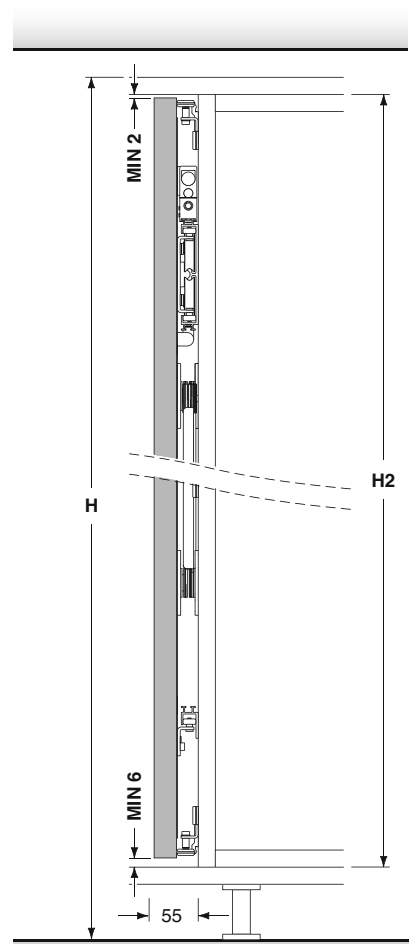
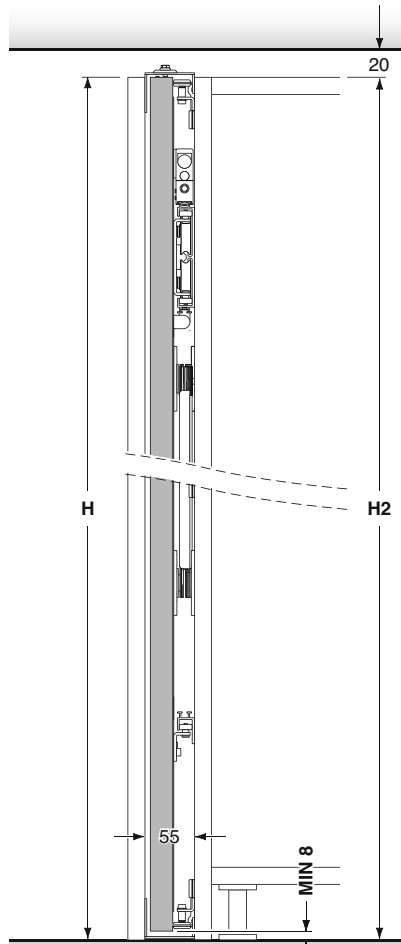
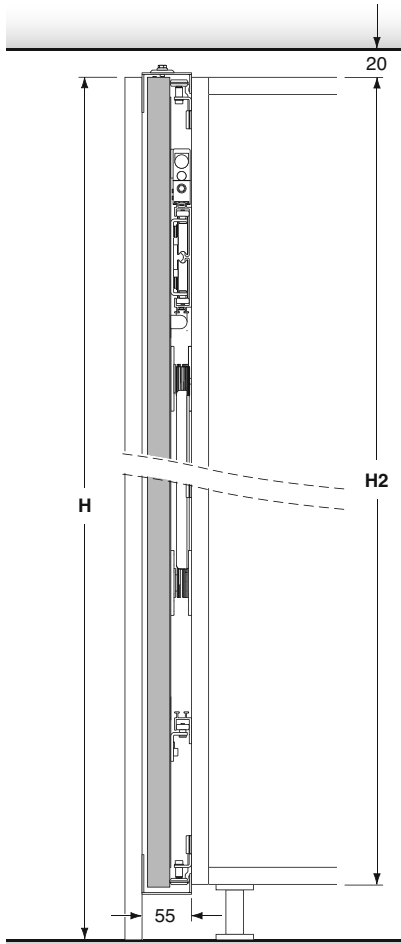

Lavorazioni per il fianco sx 550÷585 mm.

Working requests for the left side 550÷585 mm.

Usinage pour le côté gauche 550÷585 mm.

Bearbeitung für Innenseite links 550÷585 mm.

Esquema de perforación para el costado izquierdo 550÷585.

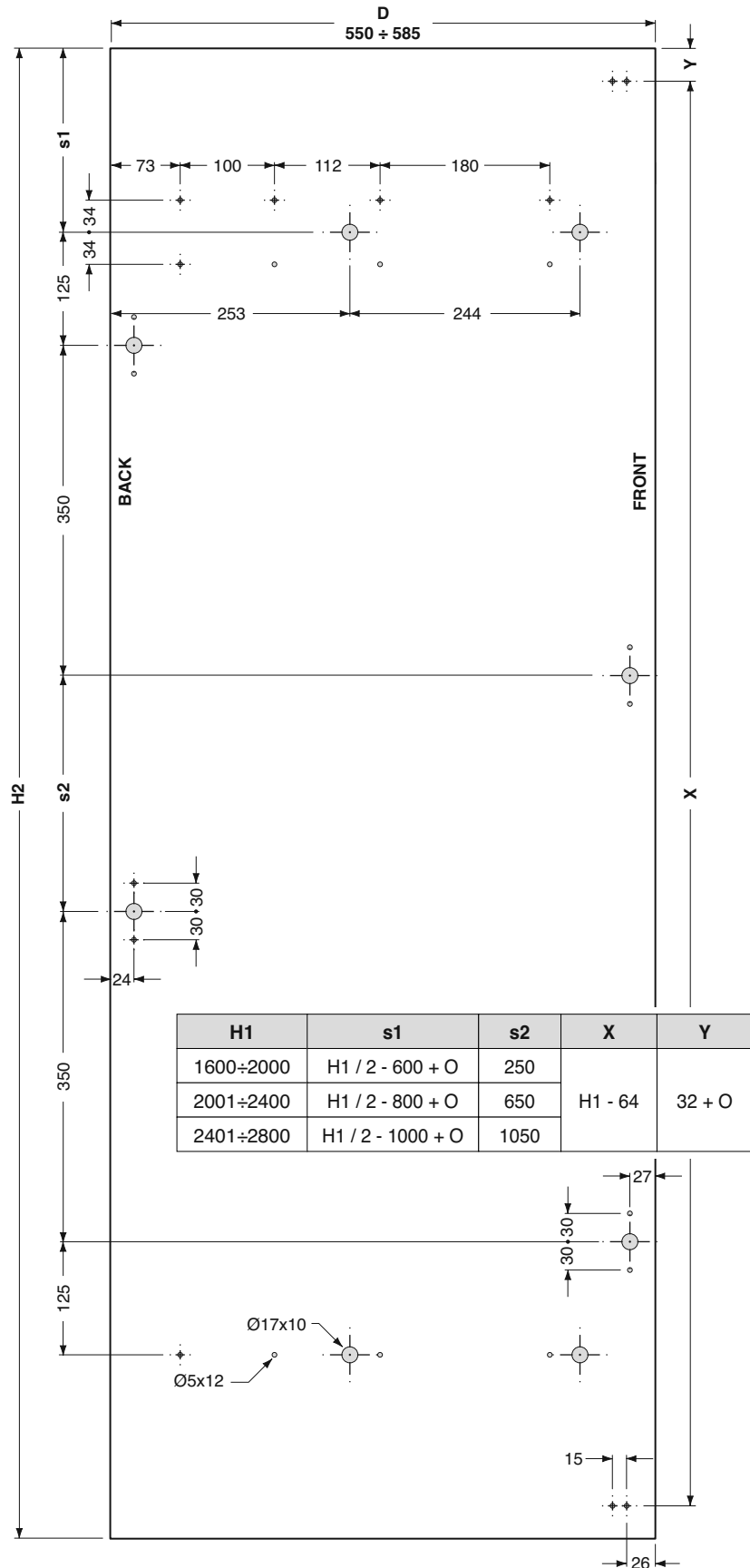
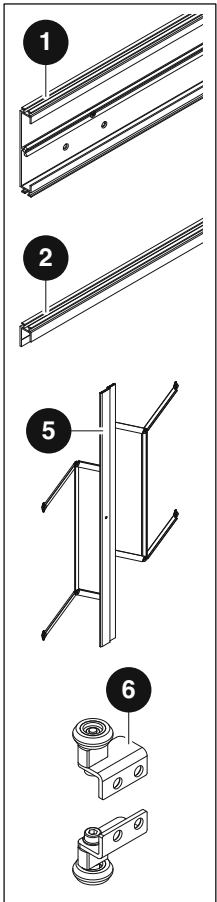
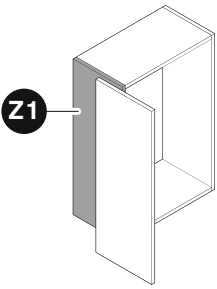

Fianco destro: speculare
Right side: mirror-like

Lavorazioni per il fianco sx 586÷685 mm.

Working requests for the left side 586÷685 mm.

Usinage pour le côté gauche 586÷685 mm.

Bearbeitung für Innenseite links 586÷685 mm.

Esquema de perforación para el costado izquierdo 586÷685.

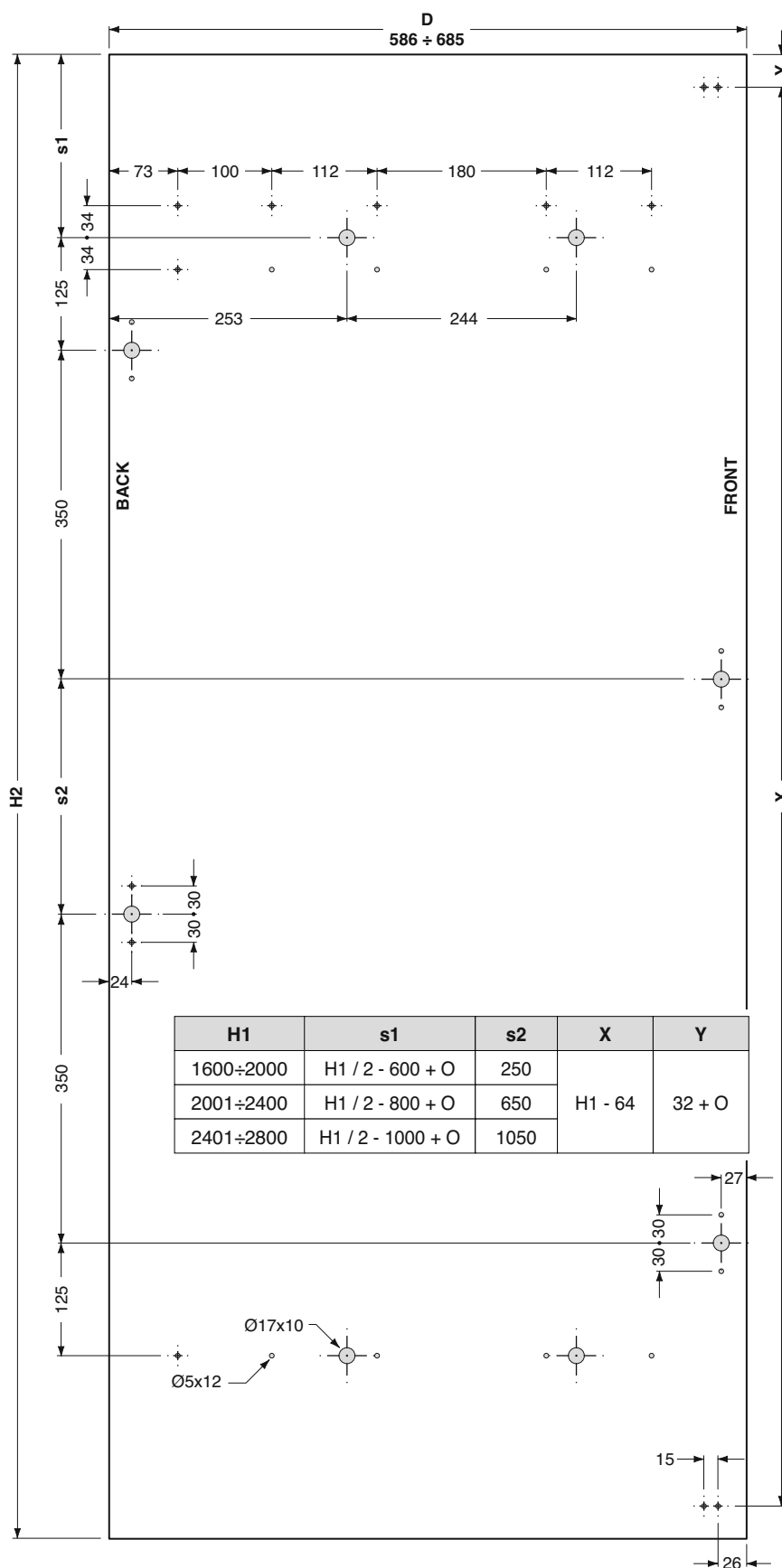
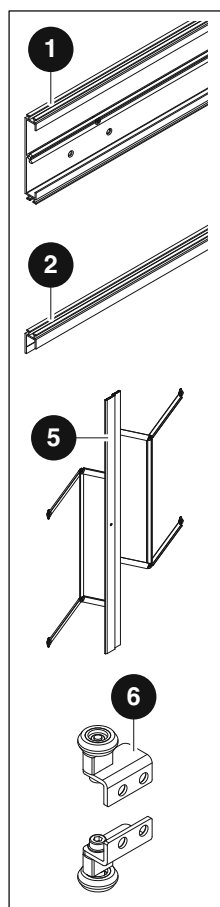
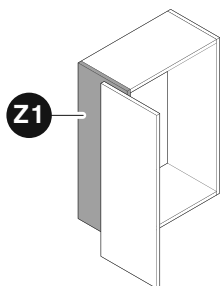

Fianco destro: speculare
Right side: mirror-like

Lavorazioni per il fianco sx 686÷750 mm.

Working requests for the left side 686÷750 mm.

Usinage pour le côté gauche 686÷750 mm.

Bearbeitung für Innenseite links 686÷750 mm.

Esquema de perforación para el costado izquierdo 686÷750.

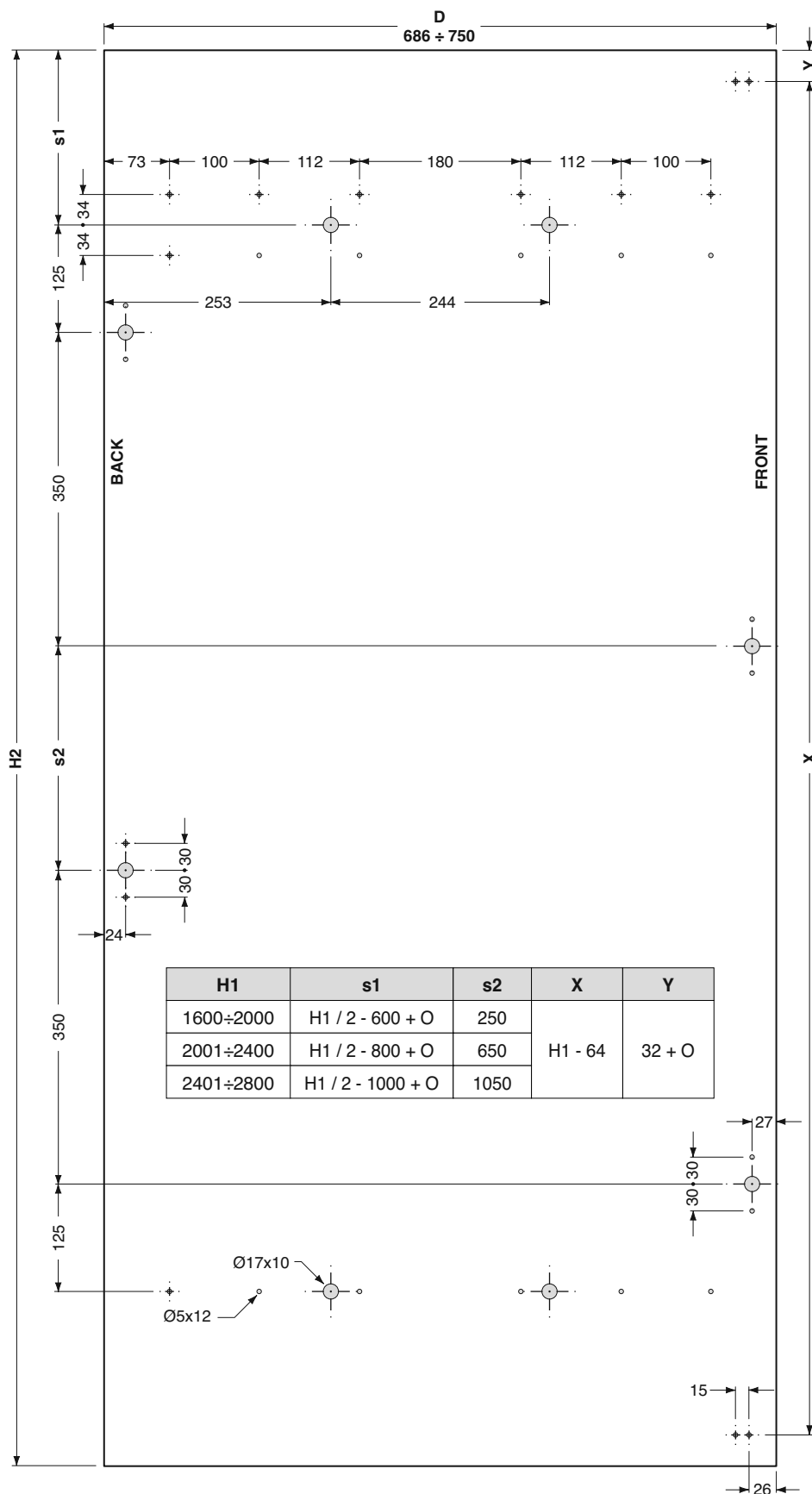
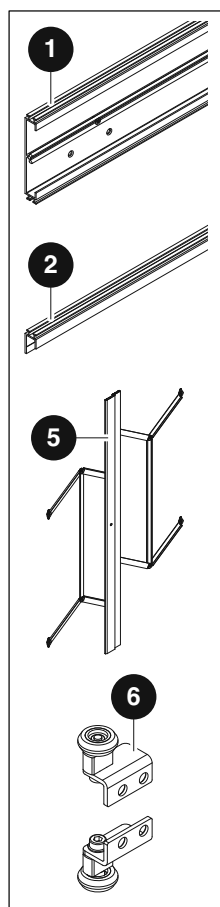
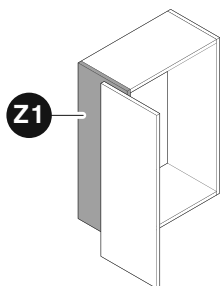

Lavorazioni per il fianco sx ≥ 751 mm.

Working requests for the left side ≥ 751 mm.

Usinage pour le côté gauche ≥ 751 mm.

Bearbeitung für Innenseite linksm ≥ 751 mm.

Esquema de perforación para el costado izquierdo ≥ 751 mm.

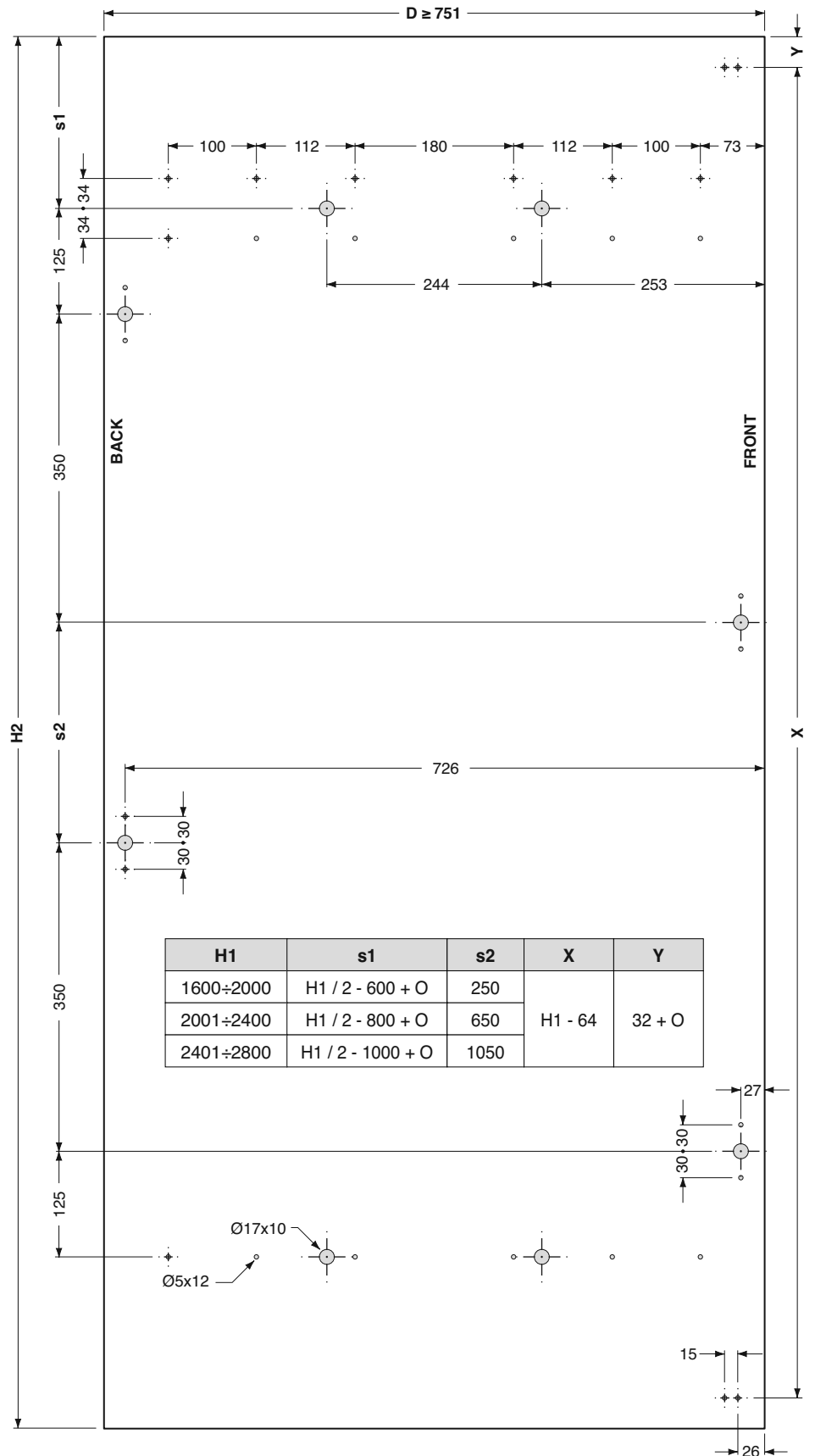
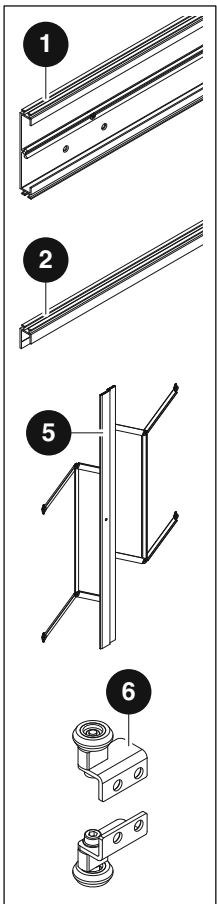
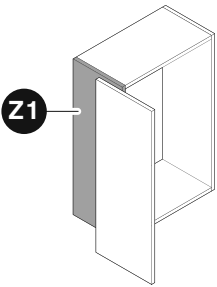

Fianco destro: speculare
Right side: mirror-like

Lavorazioni aggiuntive per il fianco sx in caso di applicazione del profilo cover.

Additional machining for the left side with cover profile.

Usinage supplémentaire du côté gauche en cas d'utilisation du profile de recouvrement.

Zusätzliche Bearbeitung bei Verwendung des Abdeckprofils links.

Mecanizados adicionales para el lado izquierdo en caso de aplicación del perfil de cobertura.

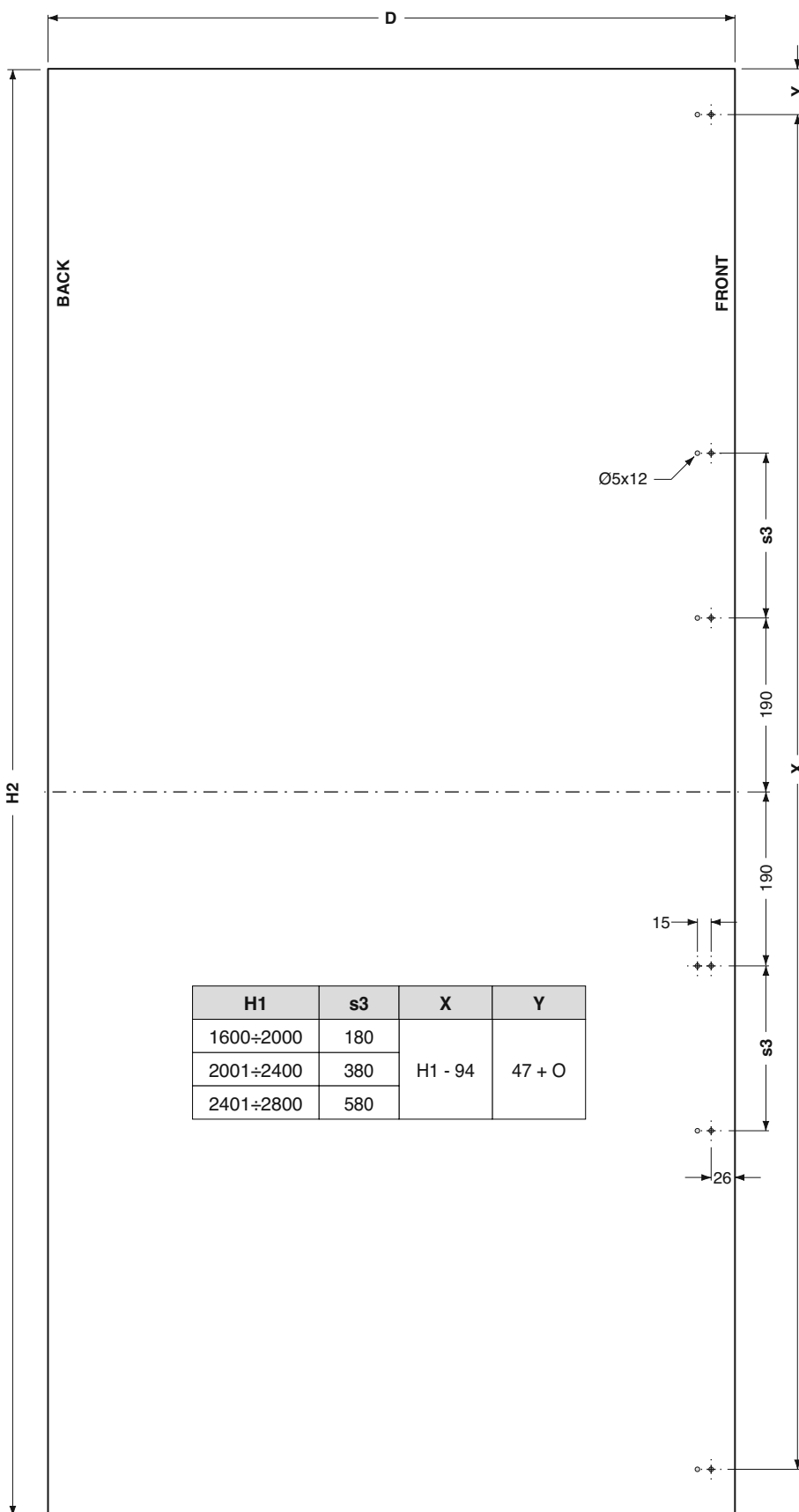
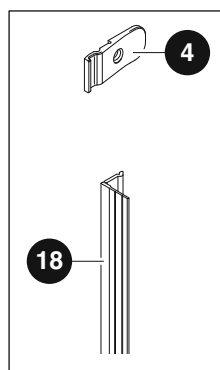
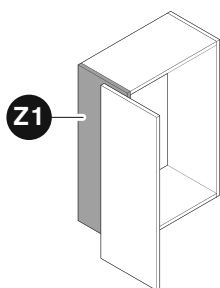

Fianco destro: speculare
Right side: mirror-like

Lavorazioni aggiuntive per il fianco sx in caso di applicazione staffe laterali.

Additional machining for the left side with lateral bracket connector.

Usinage supplémentaire du côté gauche en cas d'utilisation du connecteur latéral.

Zusätzliche Bearbeitung bei Verwendung des Verbindungprofils links.

Mecanizados adicionales para el costado izquierdo en caso de aplicación de soportes laterales.

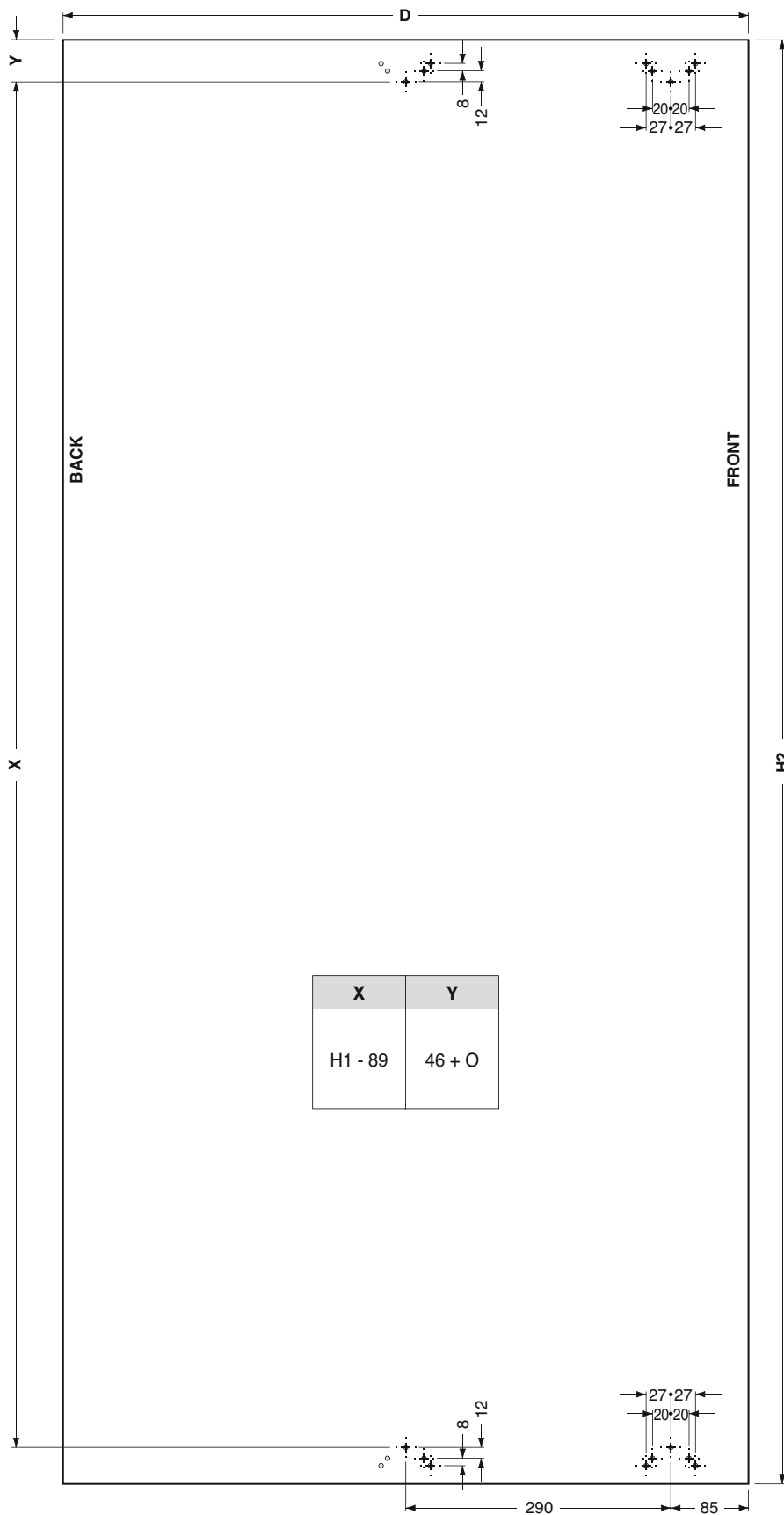
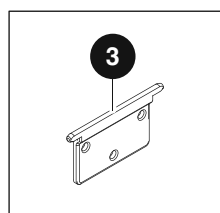
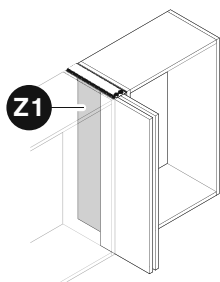
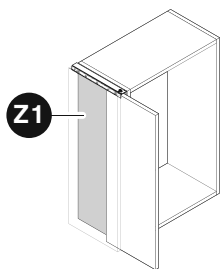

X	Y
H1 - 89	46 + O

Fianco destro: speculare
Right side: mirror-like

Lavorazioni per il pannello di copertura sx.

Working for the left cover panel.

Usinage du panneau de recouvrement Gauche.

Bearbeitung für Aussenseite links.

Mecanizados para el panel de cobertura izquierdo.

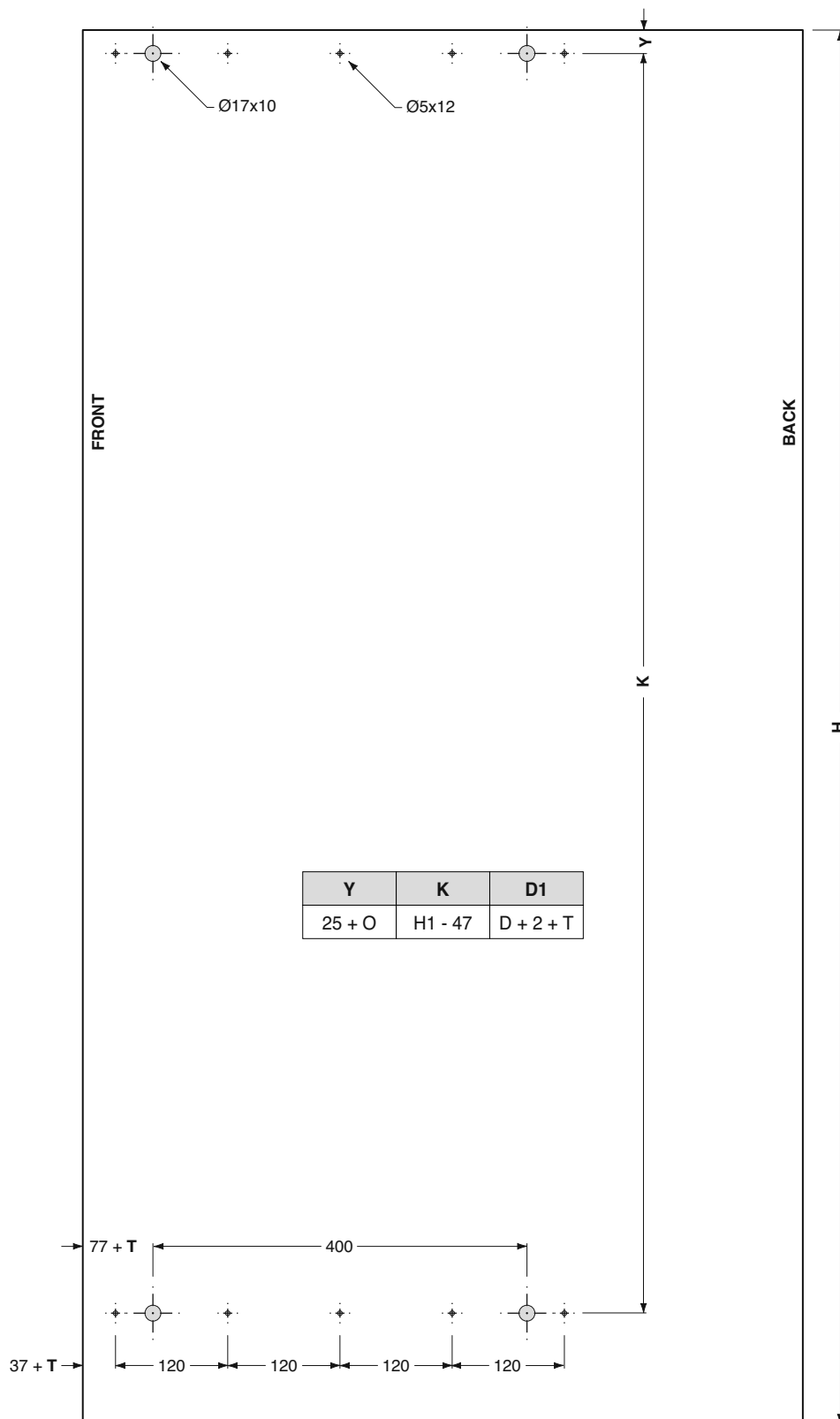
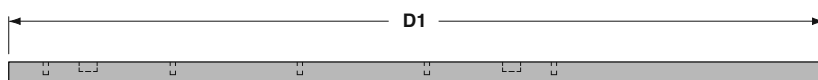
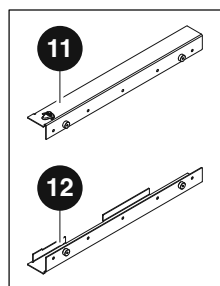
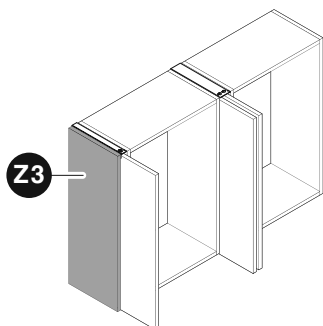
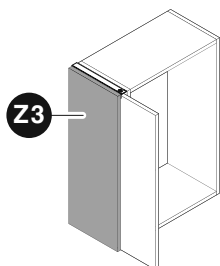

**Pannello di copertura destro:
speculare**
Cover right panel: mirror-like

Lavorazioni per l'anta sx.

Working for the left door.

Usinage de la porte gauche.

Bearbeitung für Tür links.

Mecanizados para la puerta izquierda.

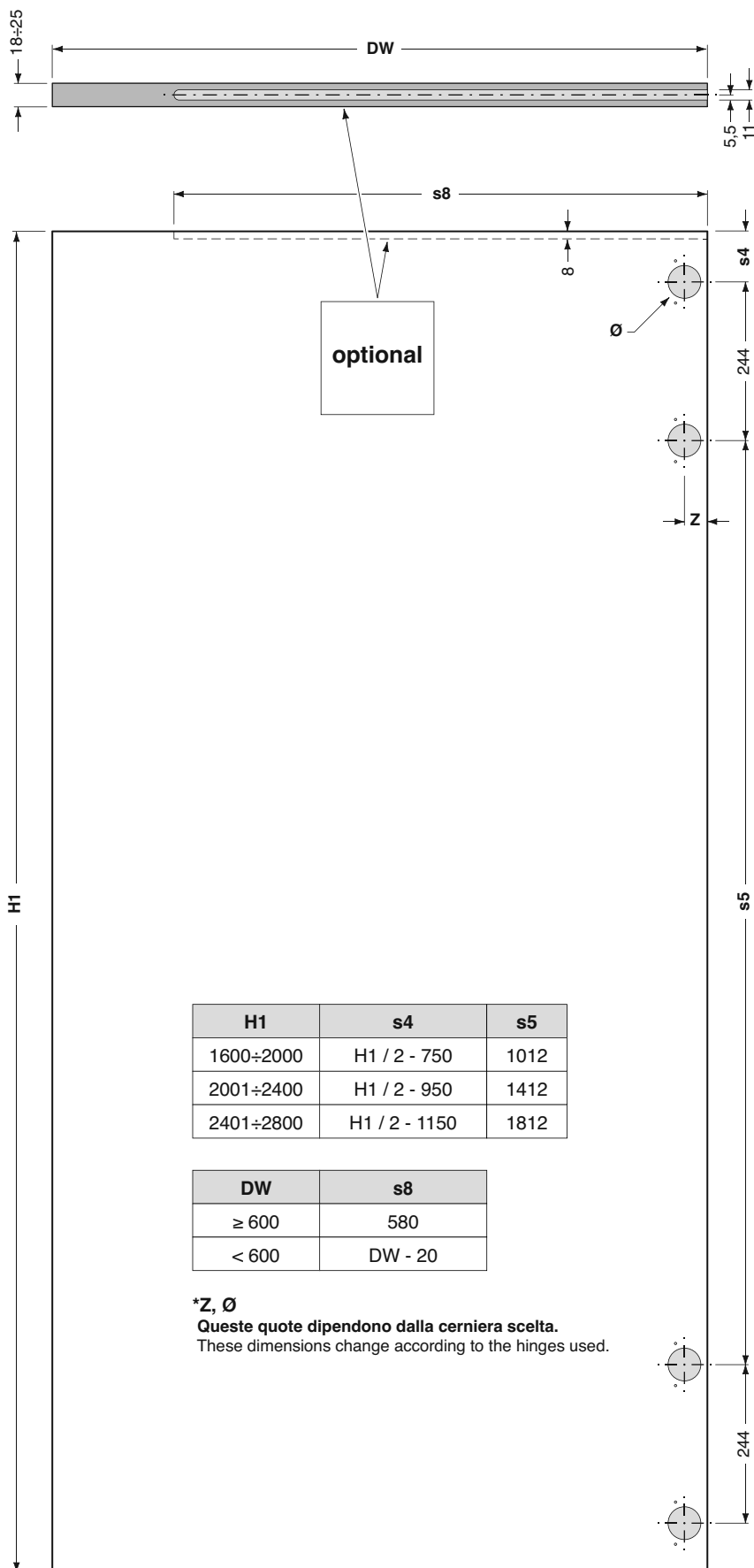
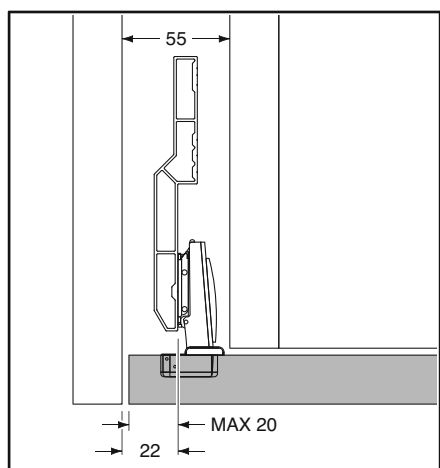
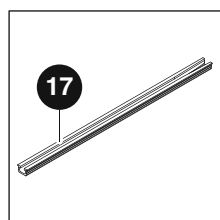
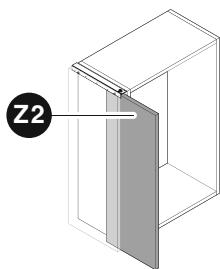

H1	s4	s5
1600÷2000	H1 / 2 - 750	1012
2001÷2400	H1 / 2 - 950	1412
2401÷2800	H1 / 2 - 1150	1812

DW	s8
≥ 600	580
< 600	DW - 20

*Z, Ø

Queste quote dipendono dalla cerniera scelta.

These dimensions change according to the hinges used.

Anta destra: speculare
Right door: mirror-like

Taglio a misura del profilo cover frontale sx.

Cut on size the front left cover.

Coupe à dimension du cache frontal gauche.

Linken Frontdichtung ablängen.

Corte a medida del perfil de cobertura frontal izquierdo.

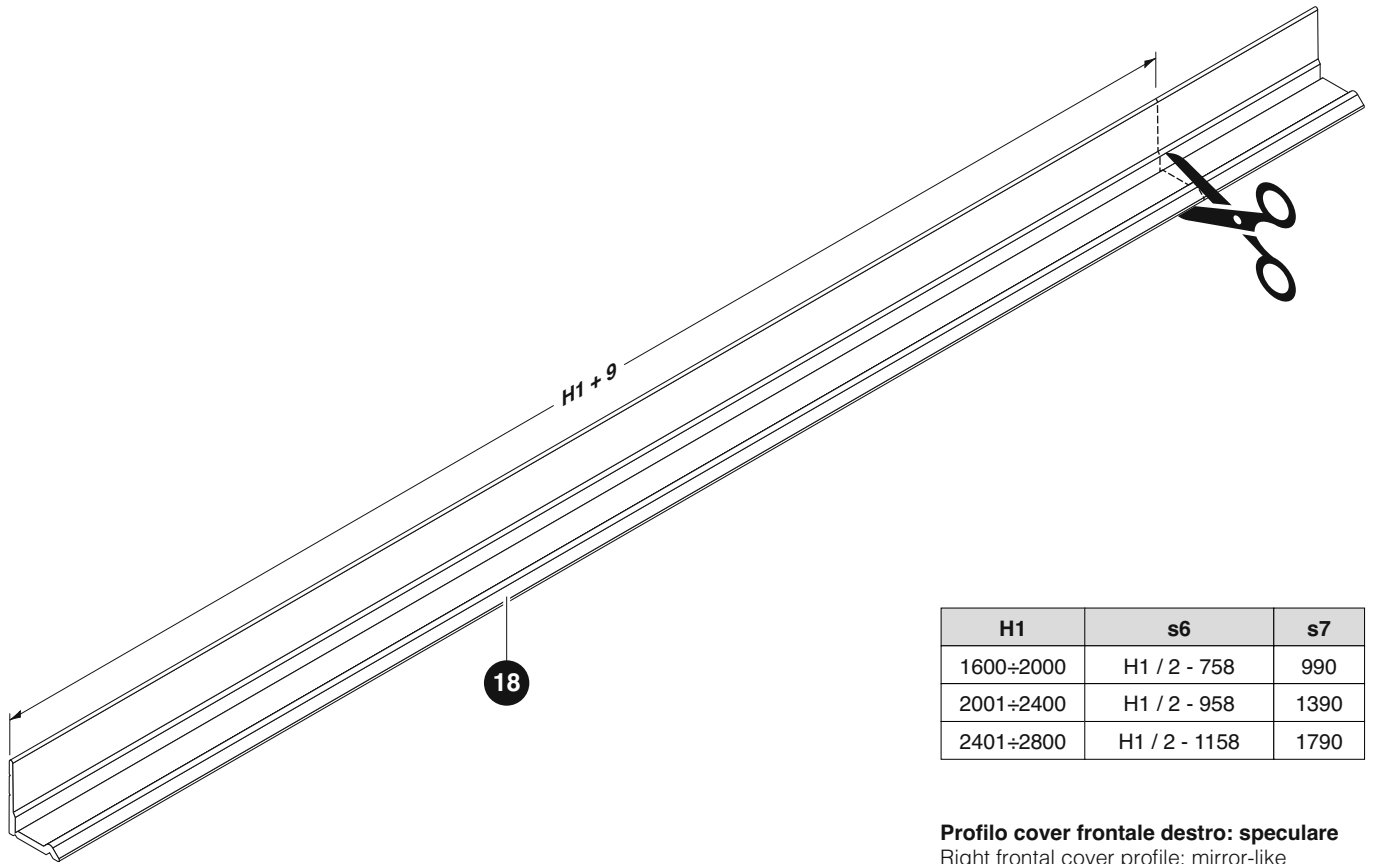

Profilo cover frontale destro: speculare
Right frontal cover profile: mirror-like

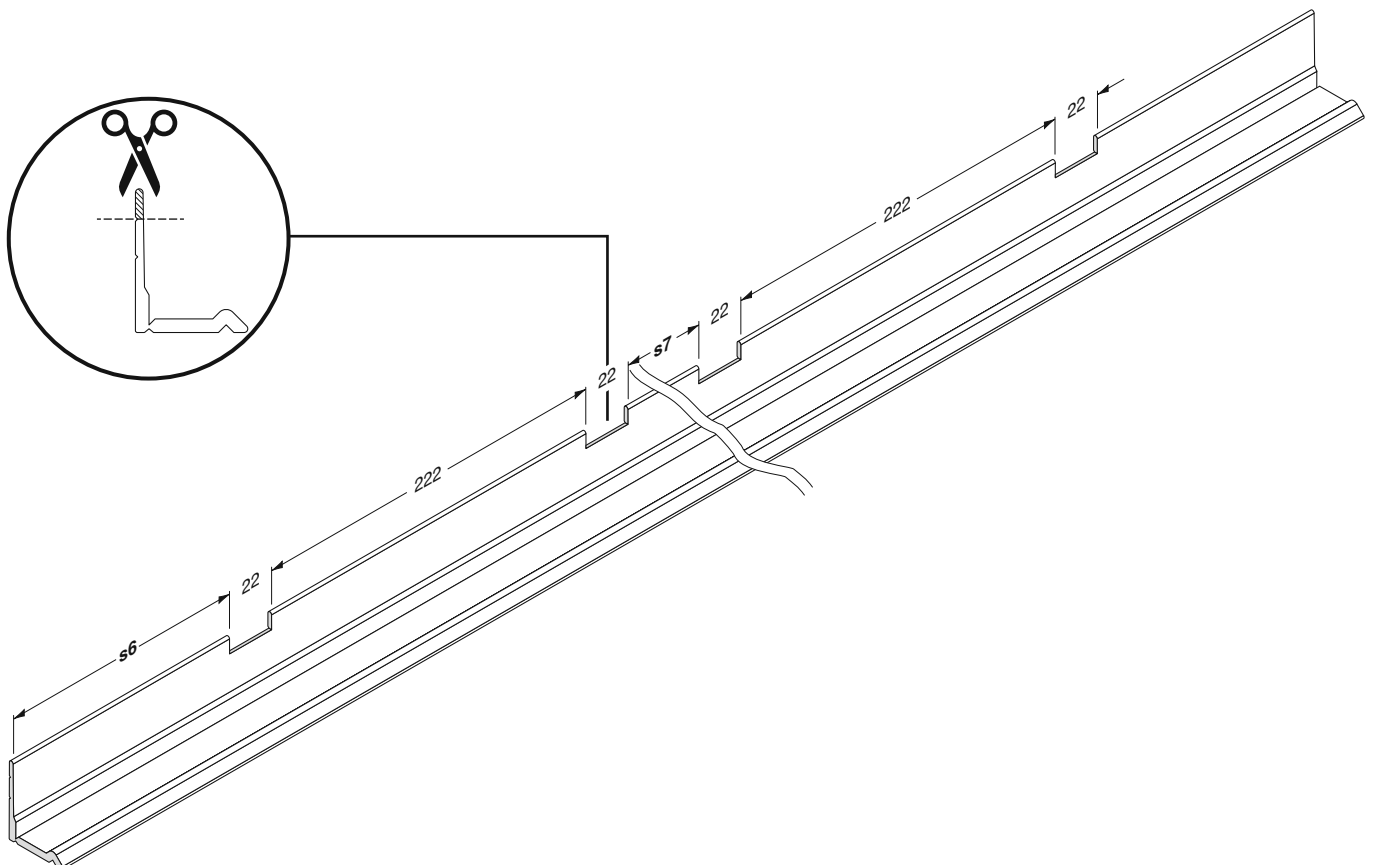

Taglio a misura dei binari.

Cut on size of the rails.

Coupe à dimension des profils.

Schienen ablängen.

Corte a medida de los rieles.



I binari devono essere tagliati sempre nella parte frontale.

Cut only front of the rails.

Les profils doivent être coupés depuis la partie avant.

Schienen vorne ablängen.

Los rieles deben ser siempre cortados en la parte frontal.

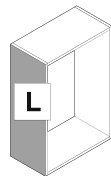
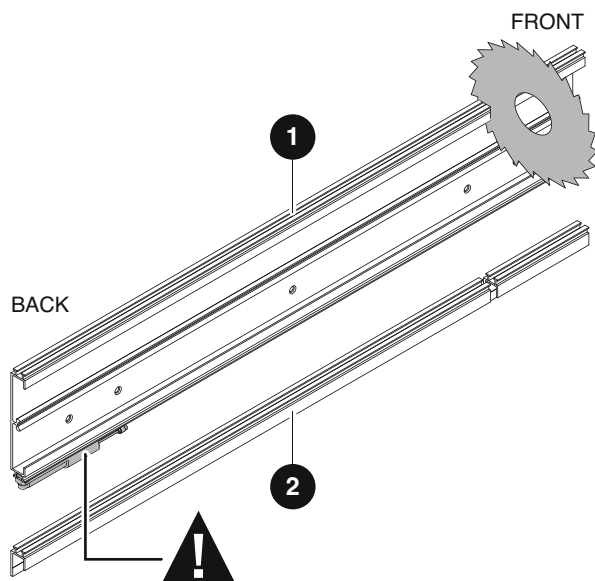

D	FD
≤ 750	D
> 750	750

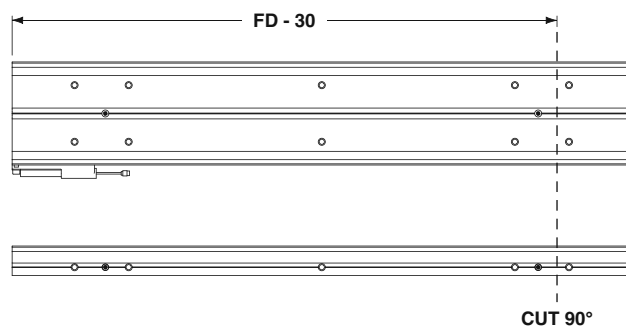

I binari devono essere tagliati sempre nella parte frontale.

Cut only front of the tracks.

Les profils doivent être coupés depuis la partie avant.

Schienen vorne ablängen.

Los rieles deben ser siempre cortados en la parte frontal.

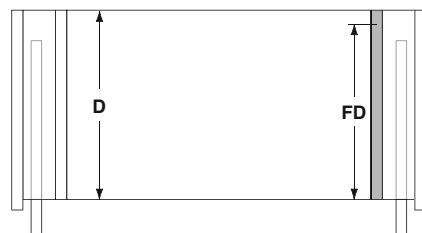
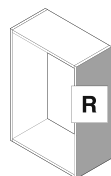
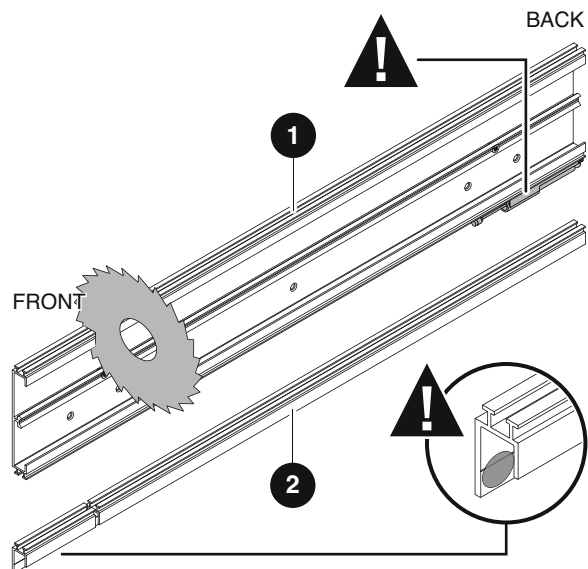

D	FD
≤ 750	D
> 750	750

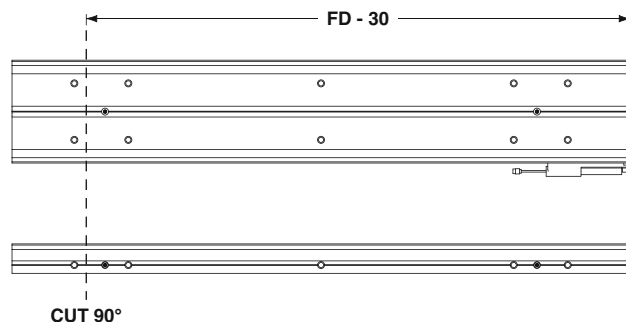

1

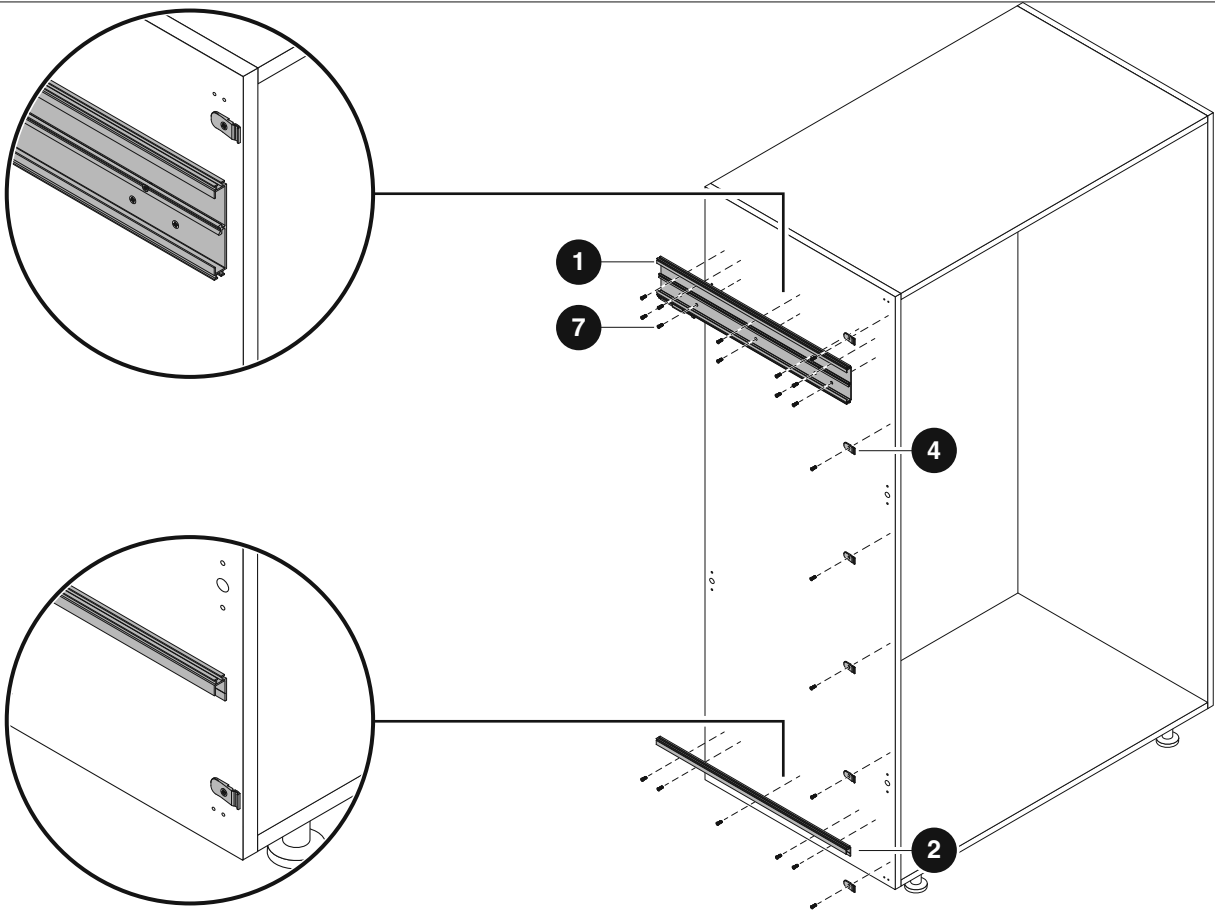

2

optional

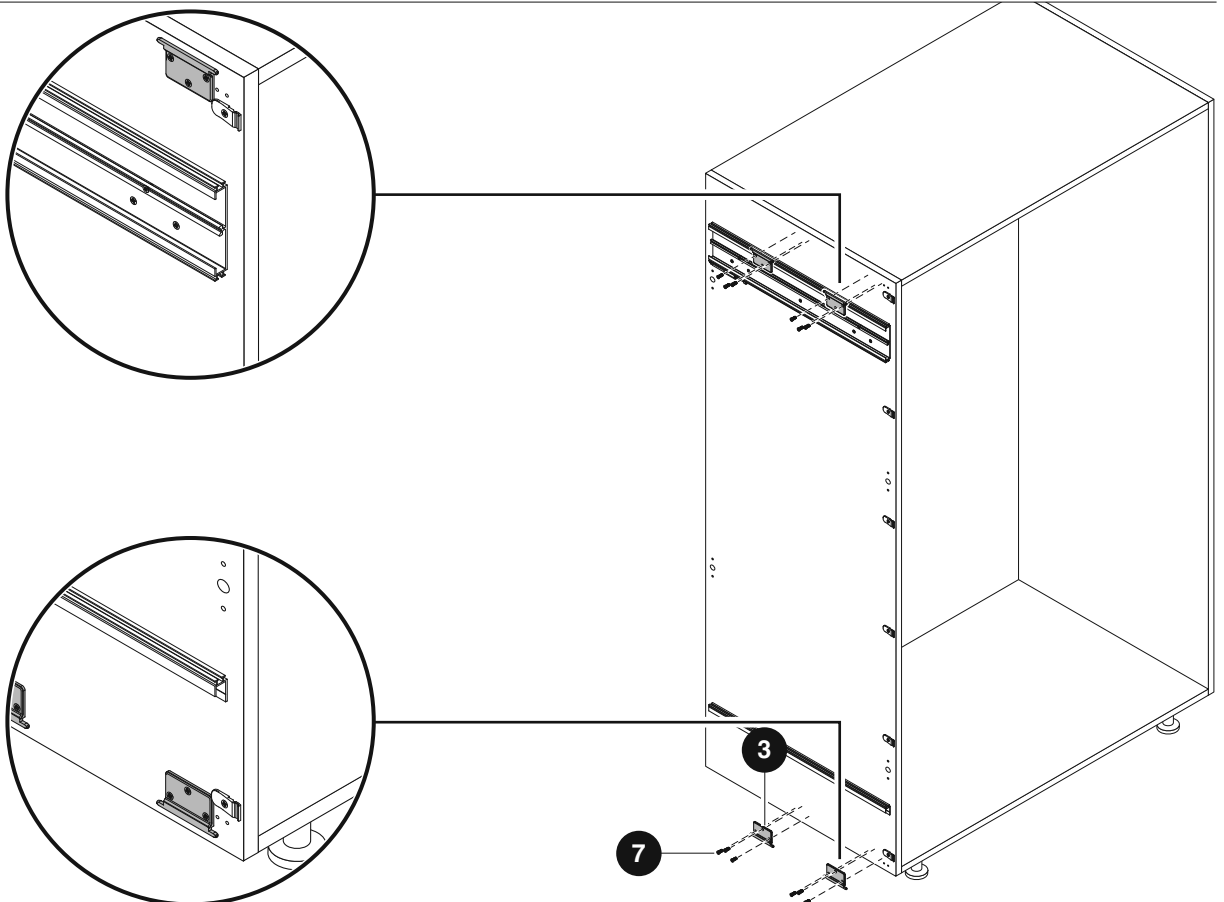

3

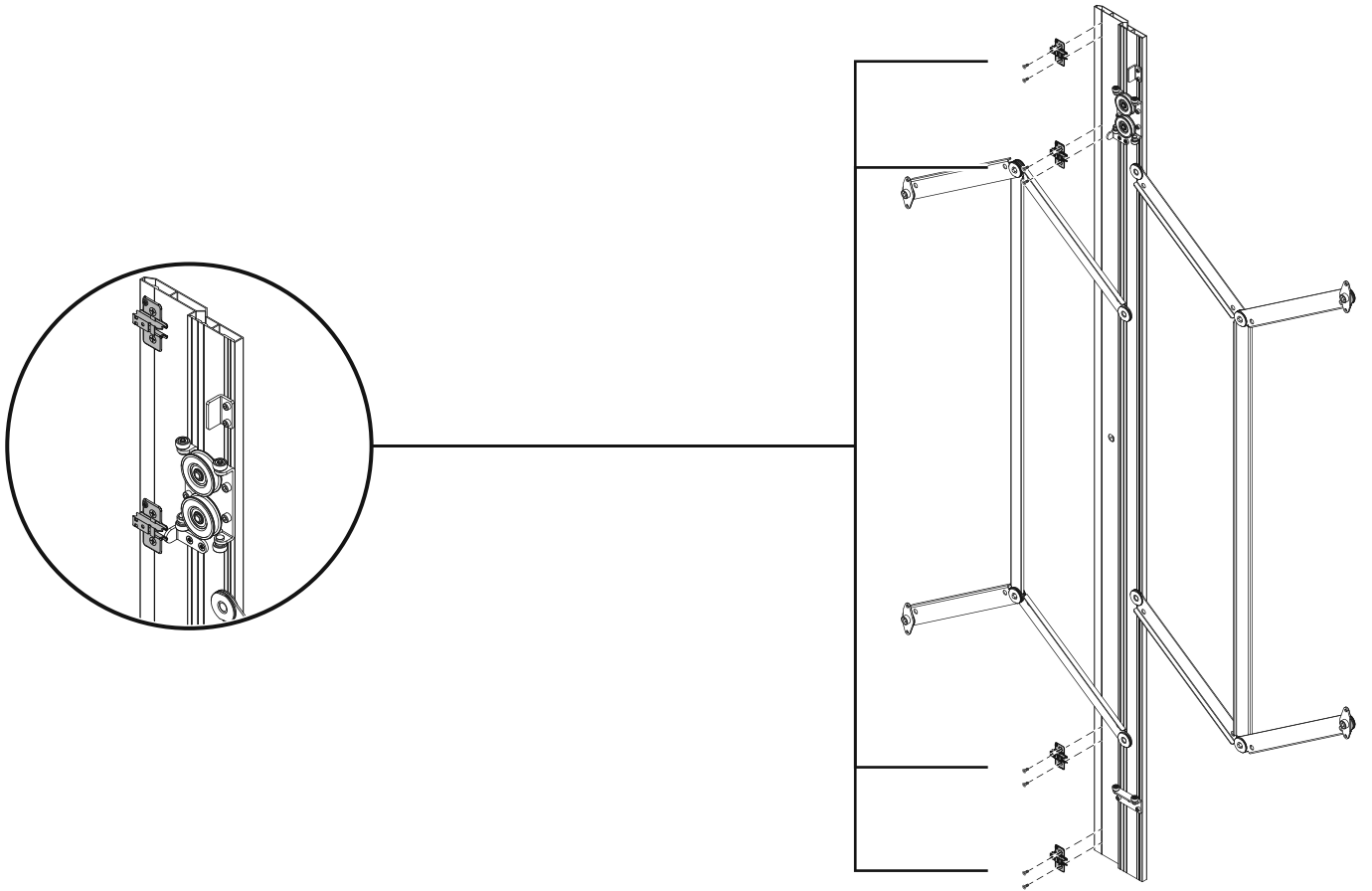

4

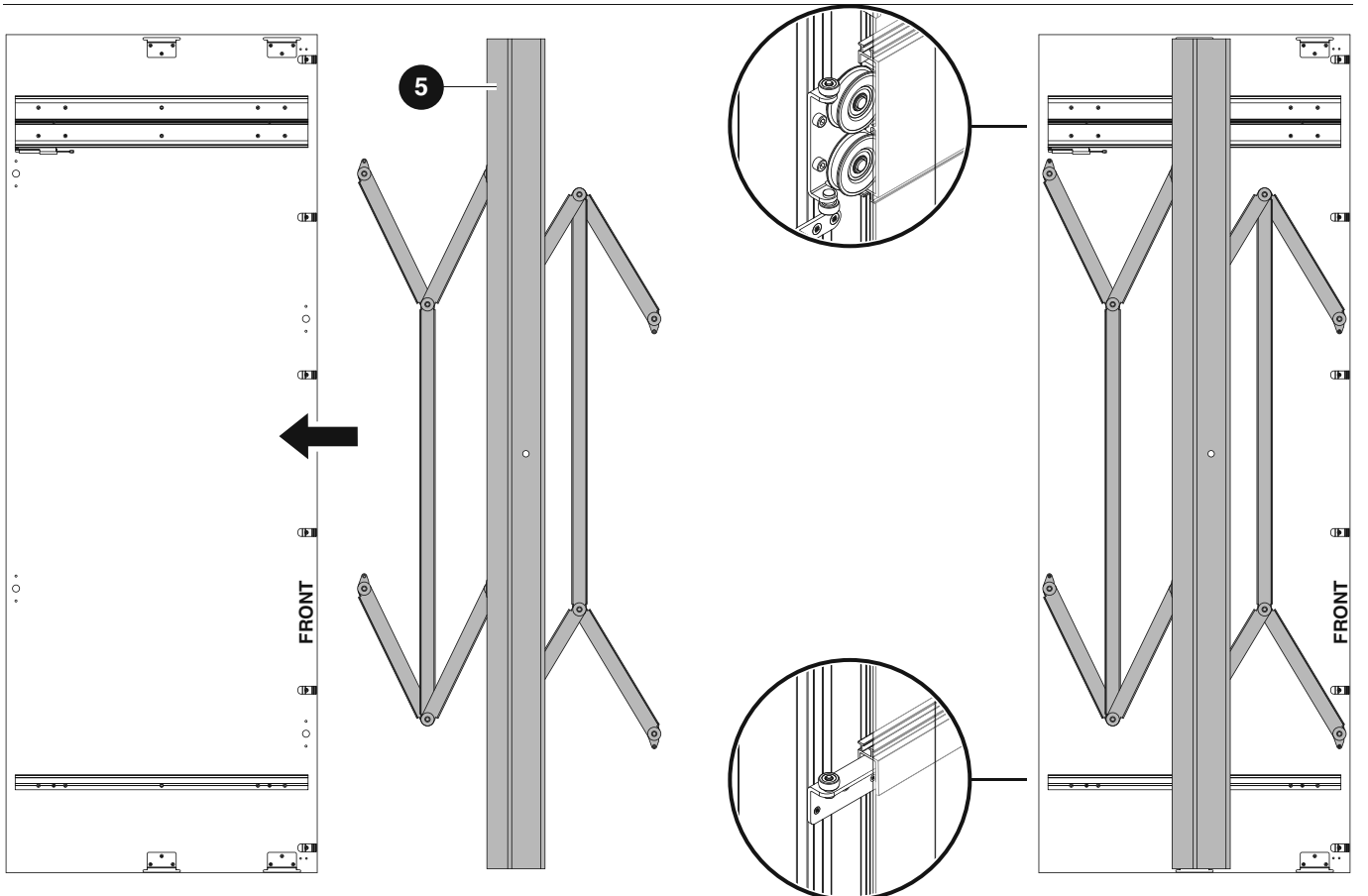

5

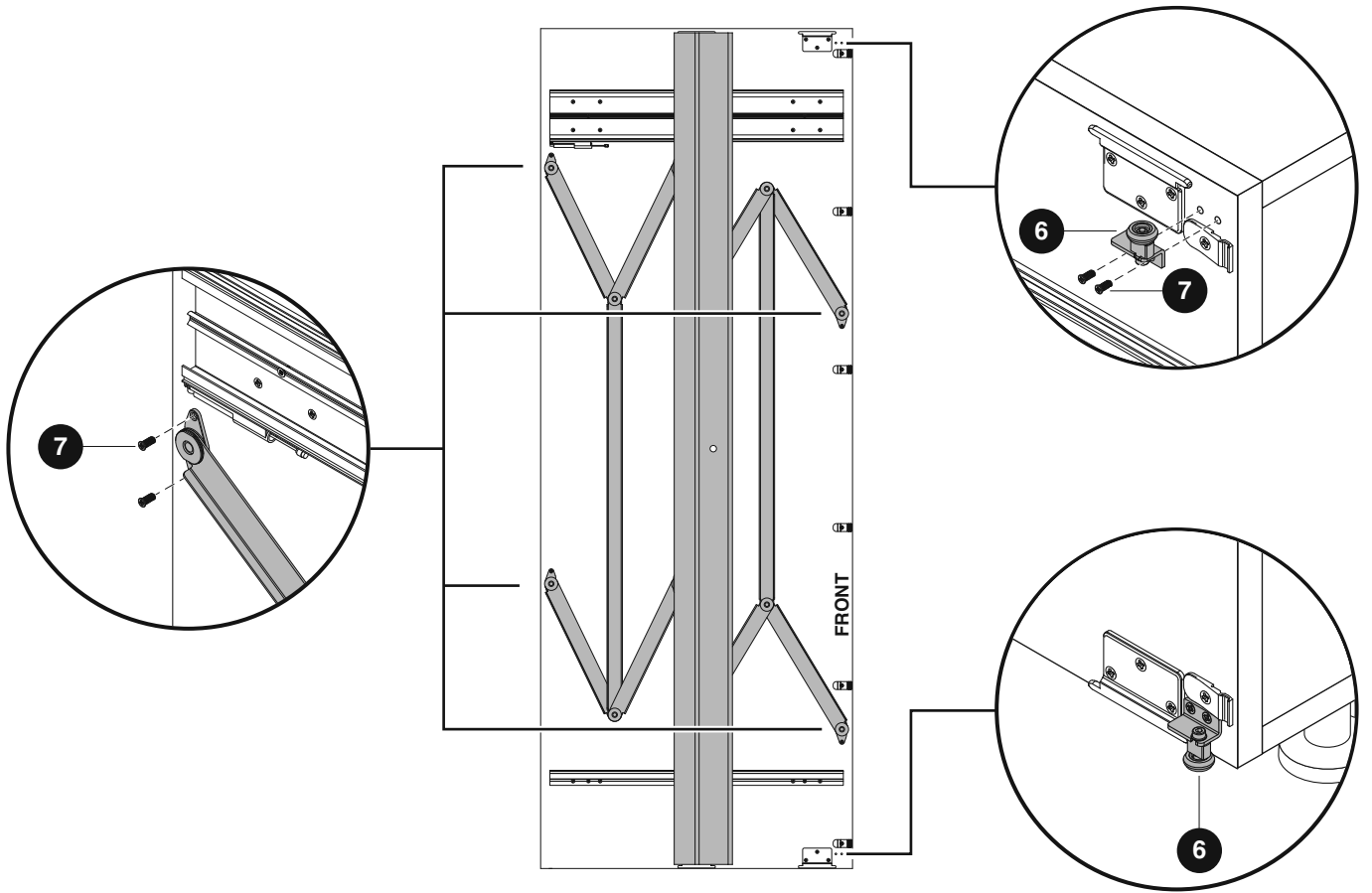

6

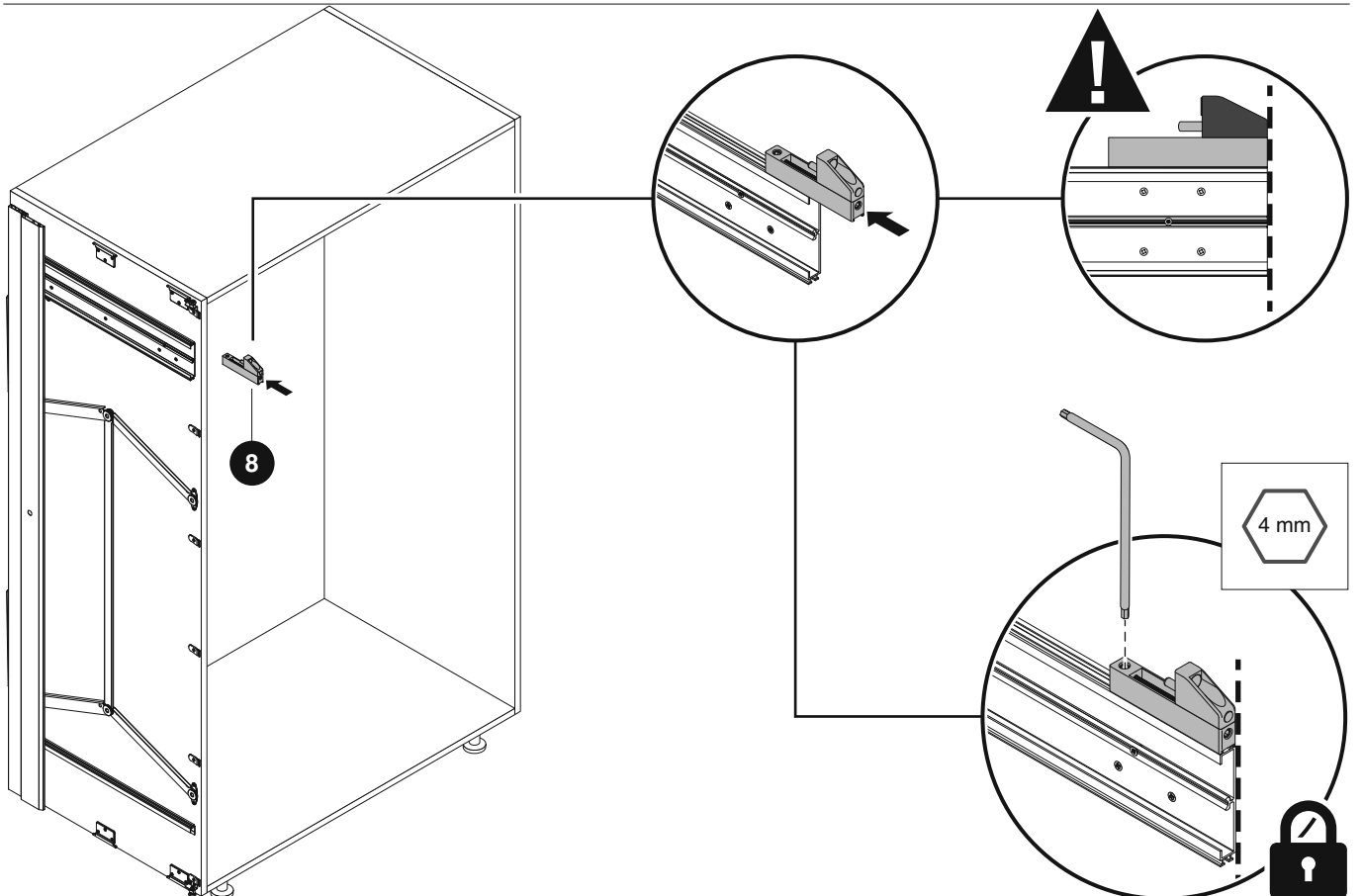

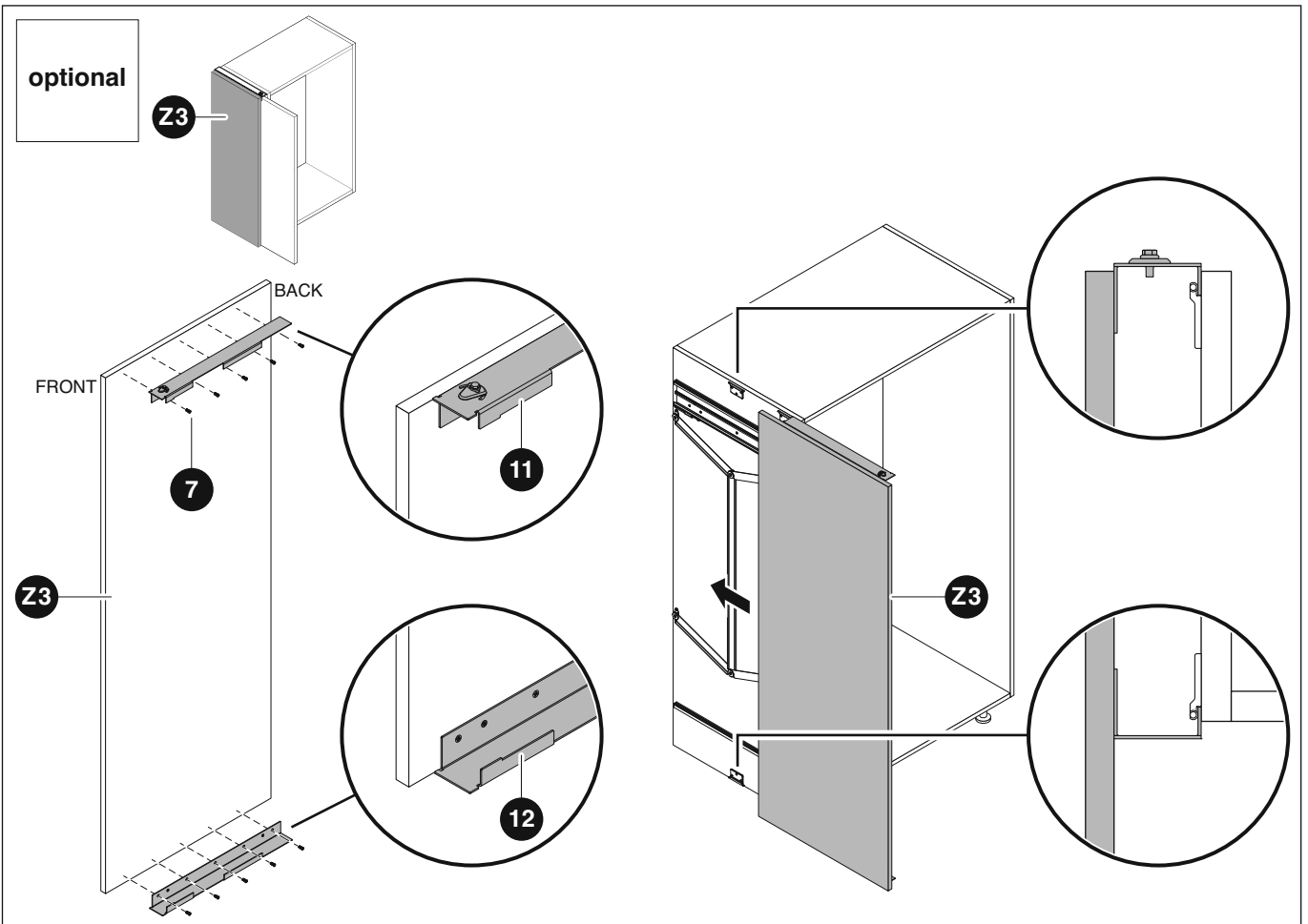
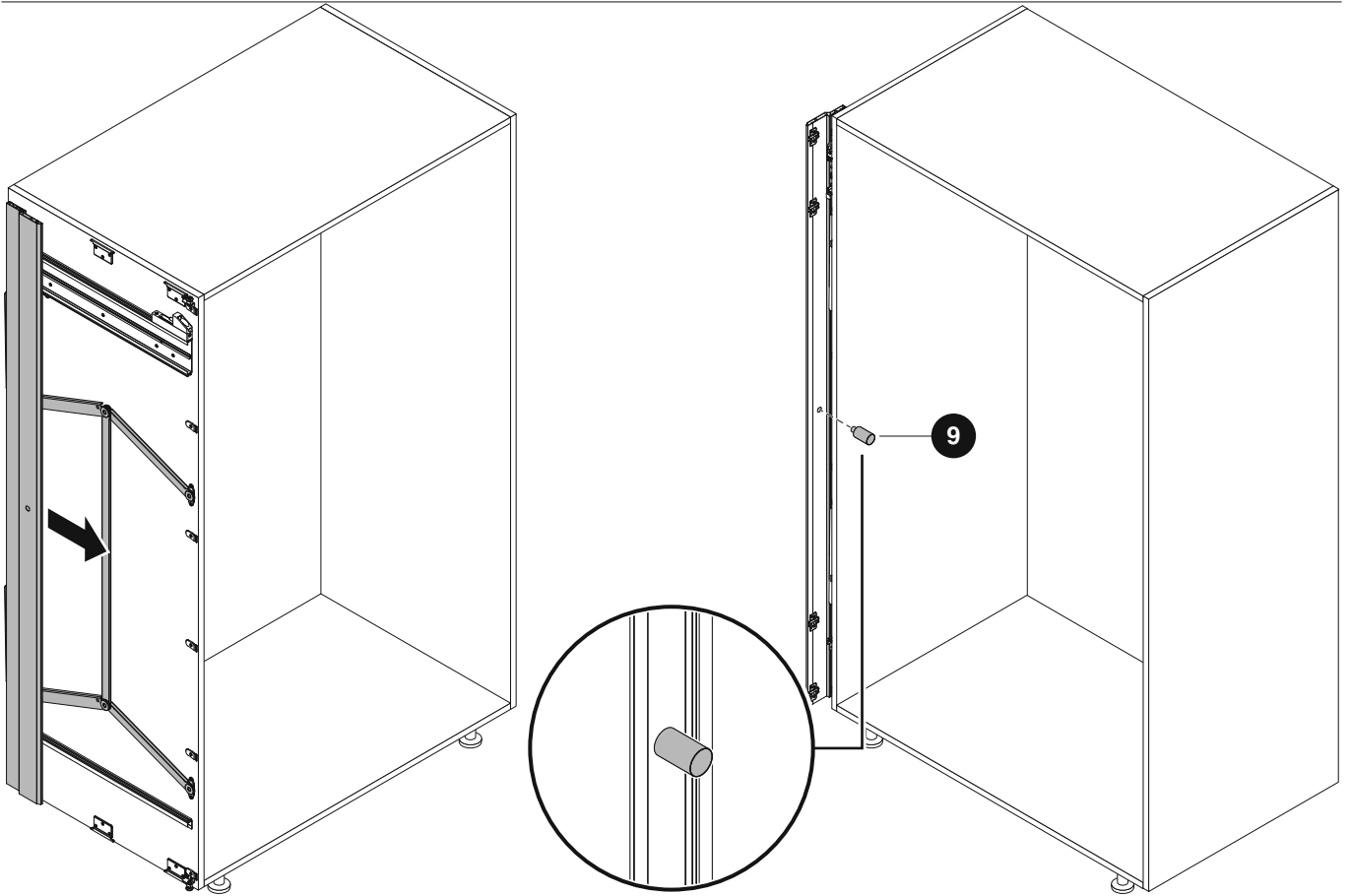

optional

Applicazione staffe di unione.

Installation of connecting bracket.

Installation du support de connexion.

Montage der Anschlusswinkel.

Instalación del soporte de conexión.

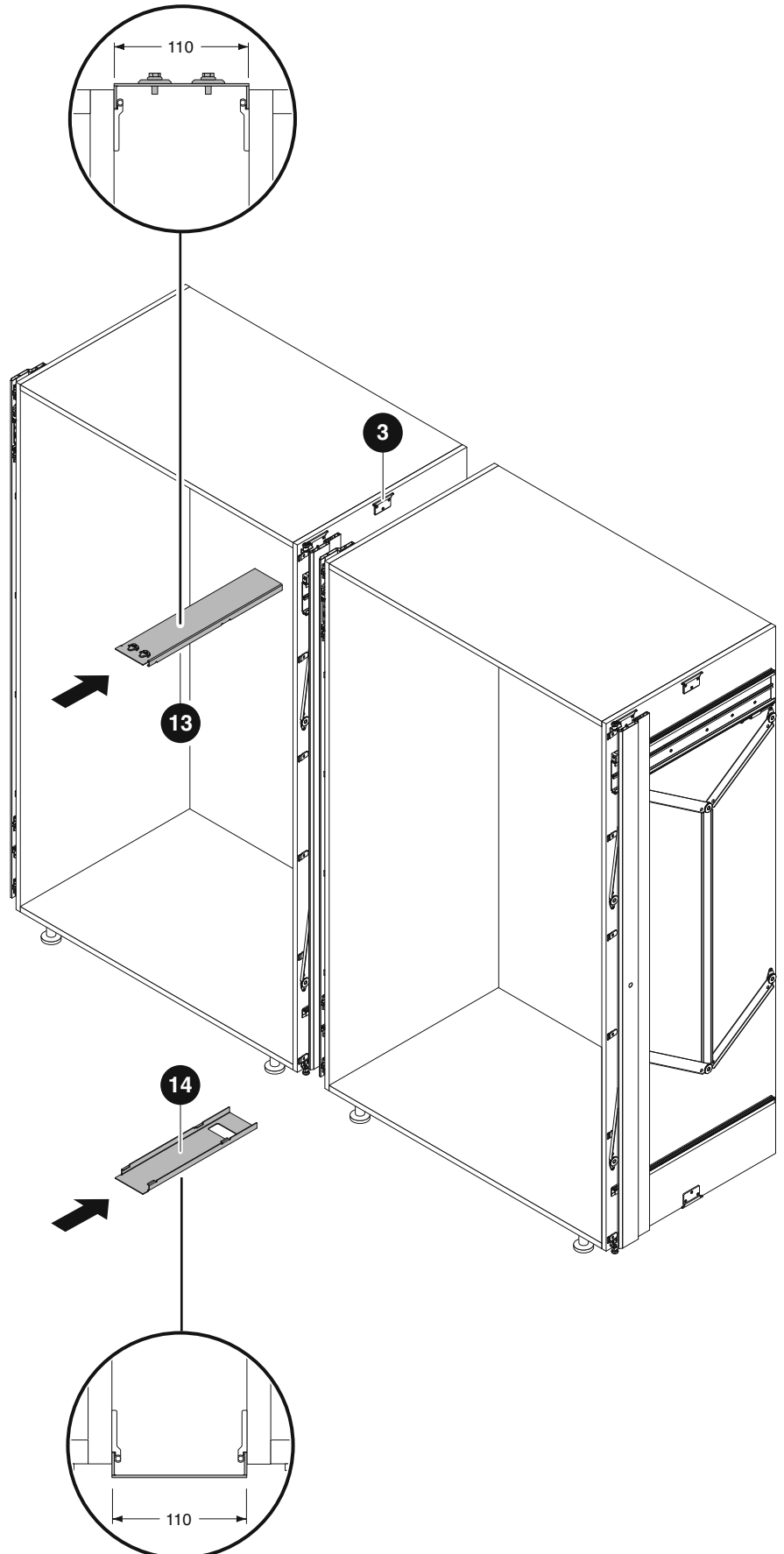
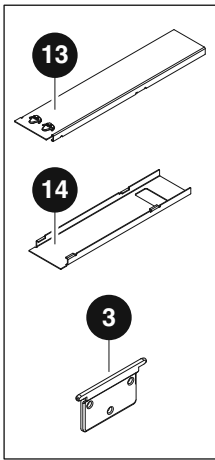
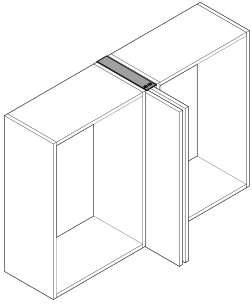

Montaggio dell'anta.

Door installation.
 Montage de la porte.
 Türmontage.
 Montaje de la puerta.

Il profilo guida deve essere tagliato sempre nella parte frontale.

Cut only front of the door track profile.
 Le profil guide doit être coupé en partie avant.
 Führungsschiene vorne ablängen.
 El perfil guía debe ser siempre cortado en la parte frontal.

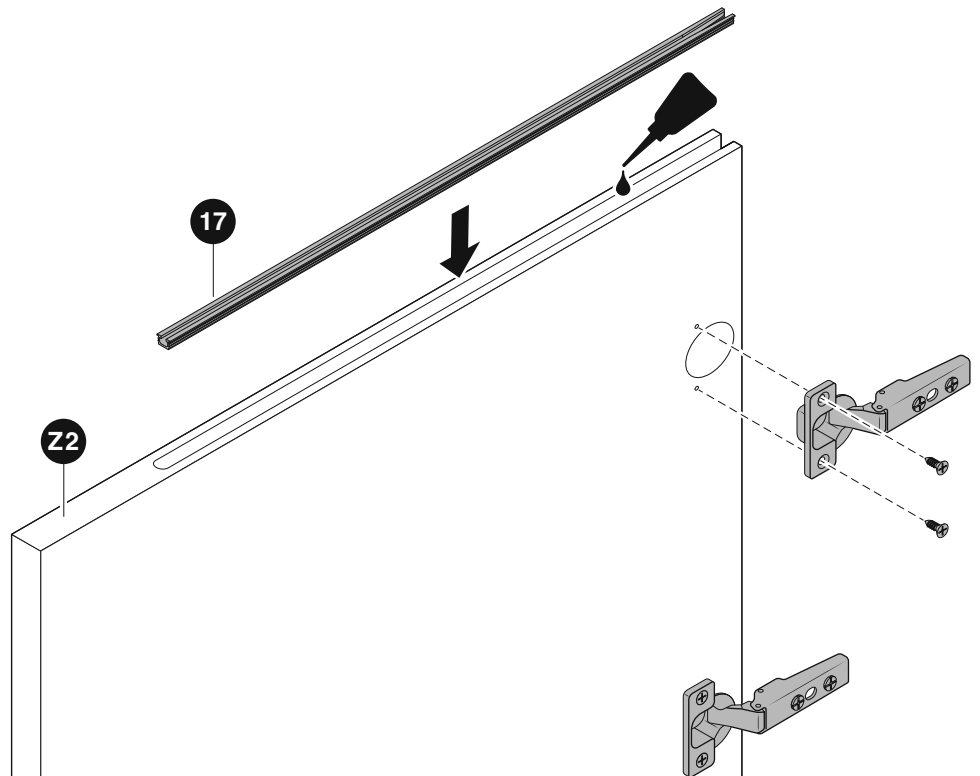
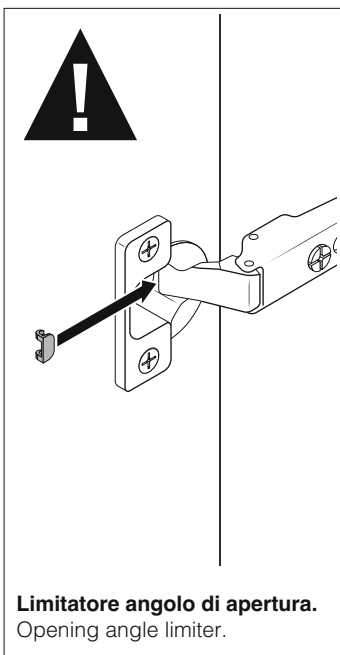
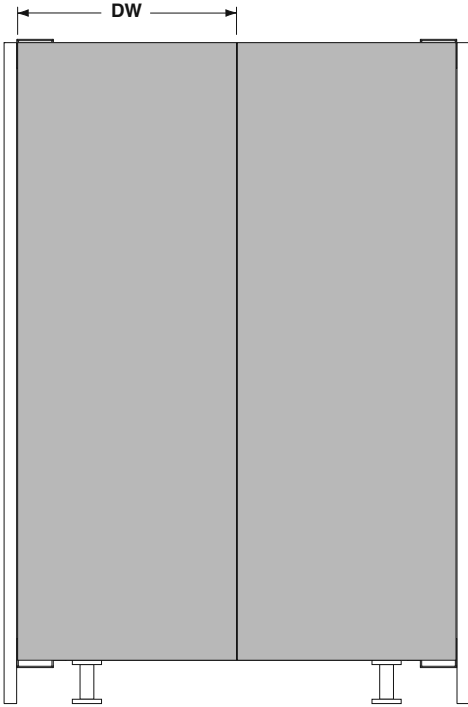
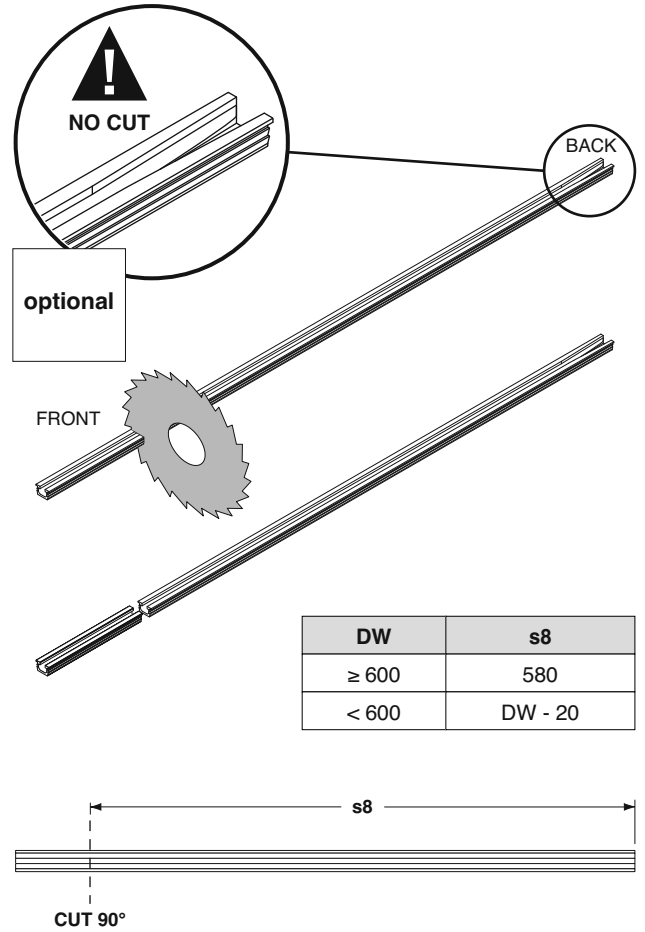

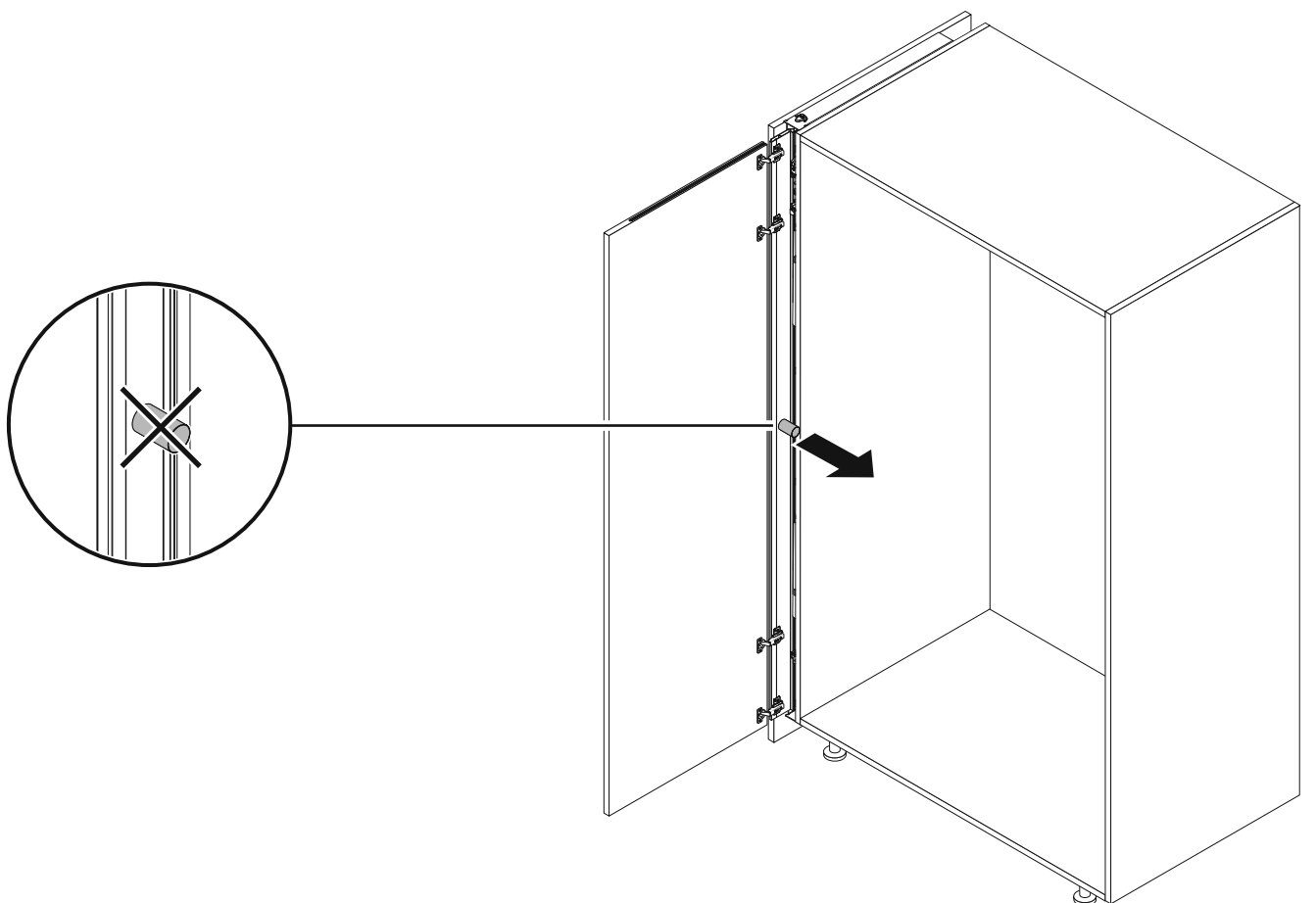
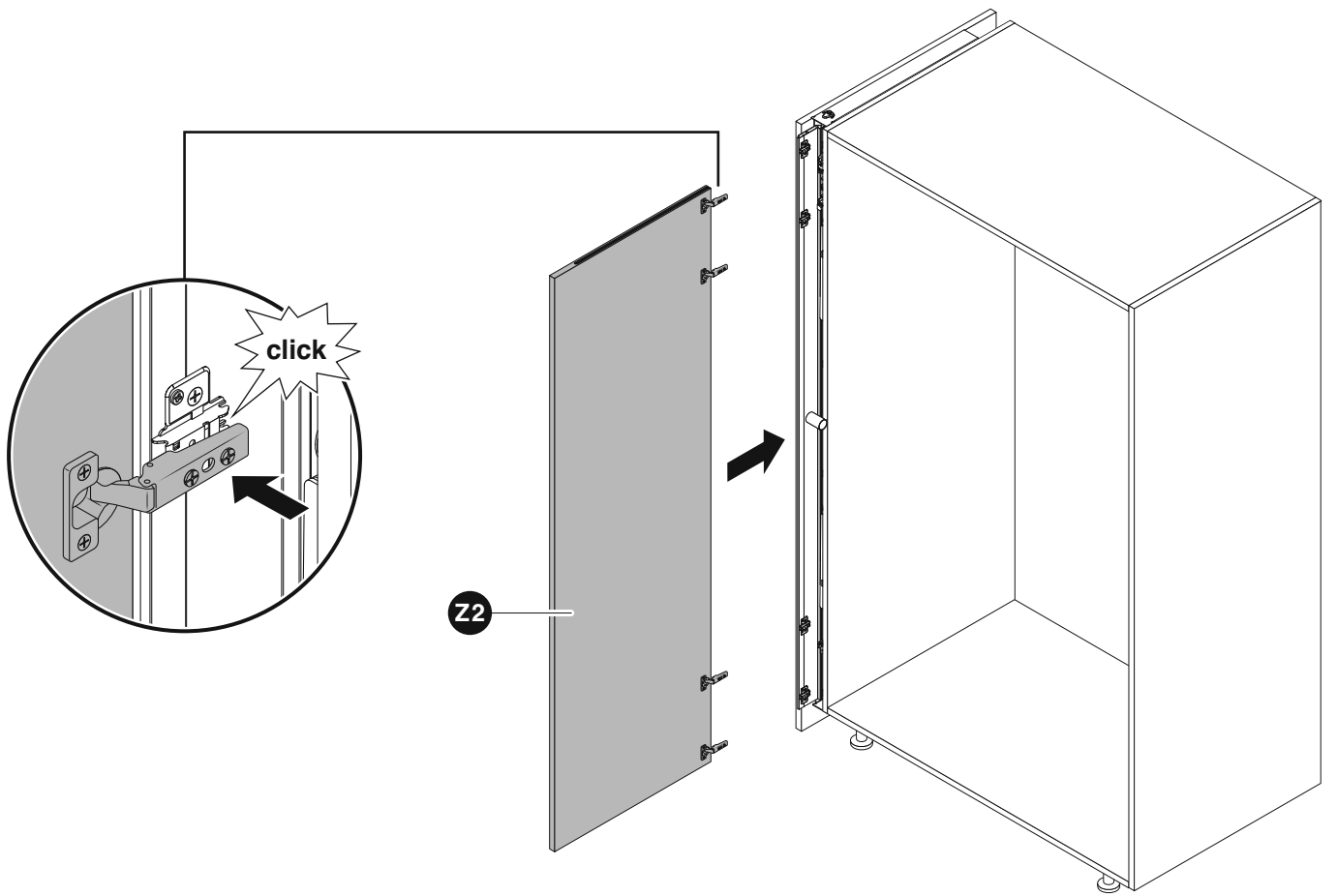

Regolazioni dell'anta.

Door adjustment

Réglage de la port.

Tür einstellen.

Ajustes de la puerta.

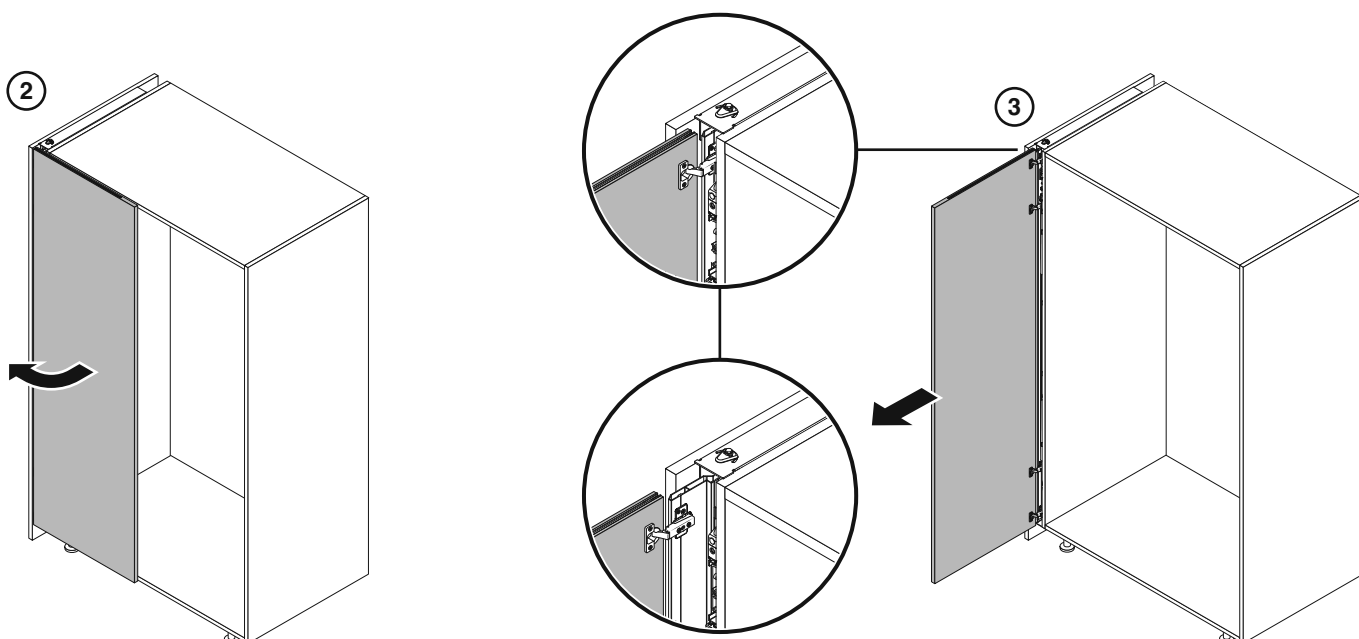
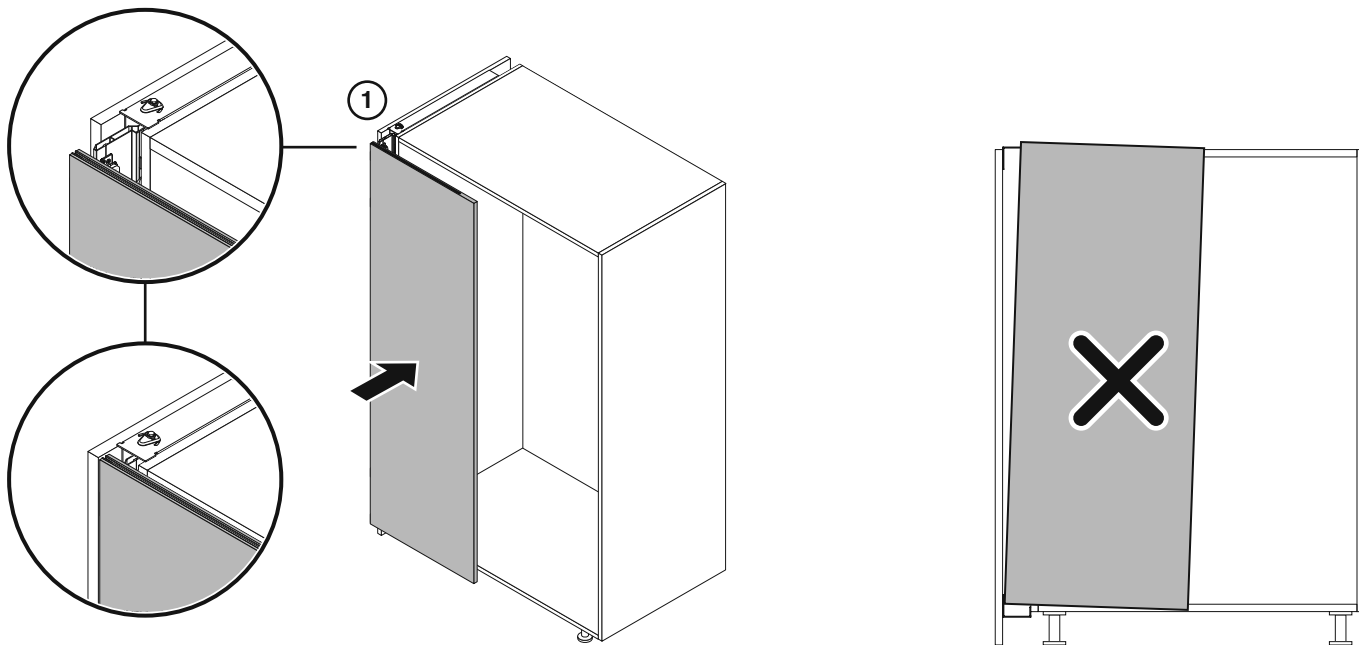

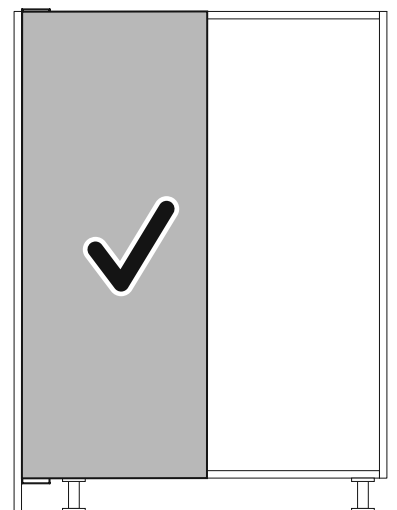
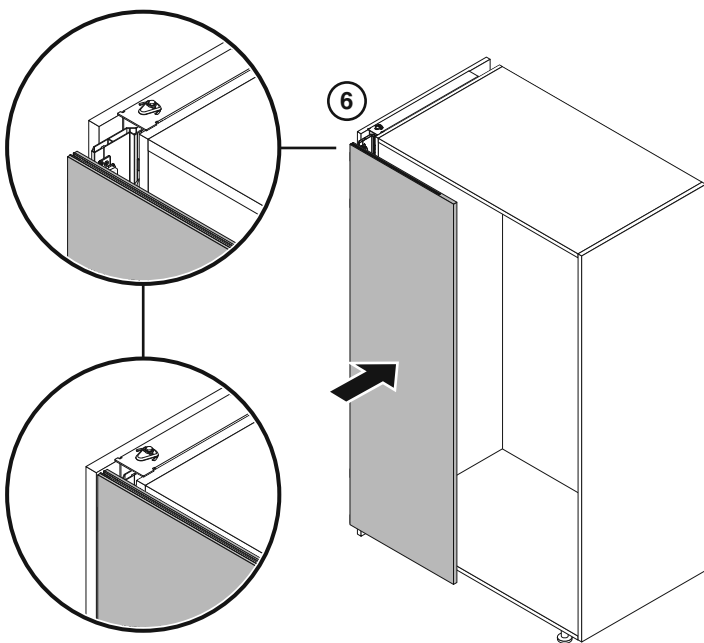
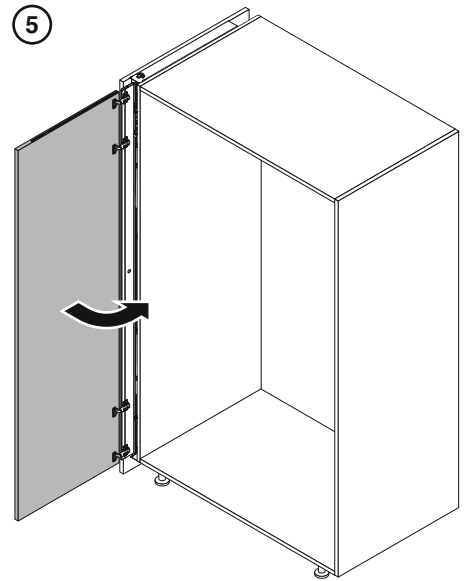
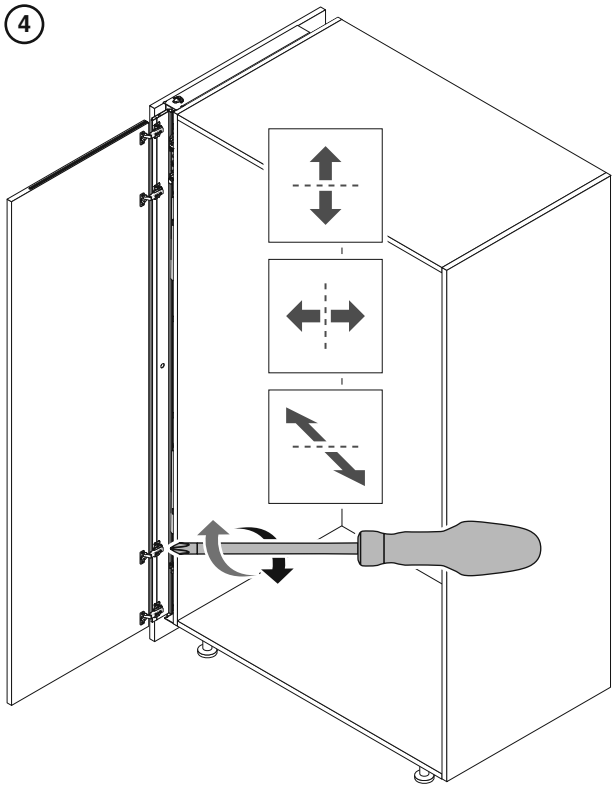

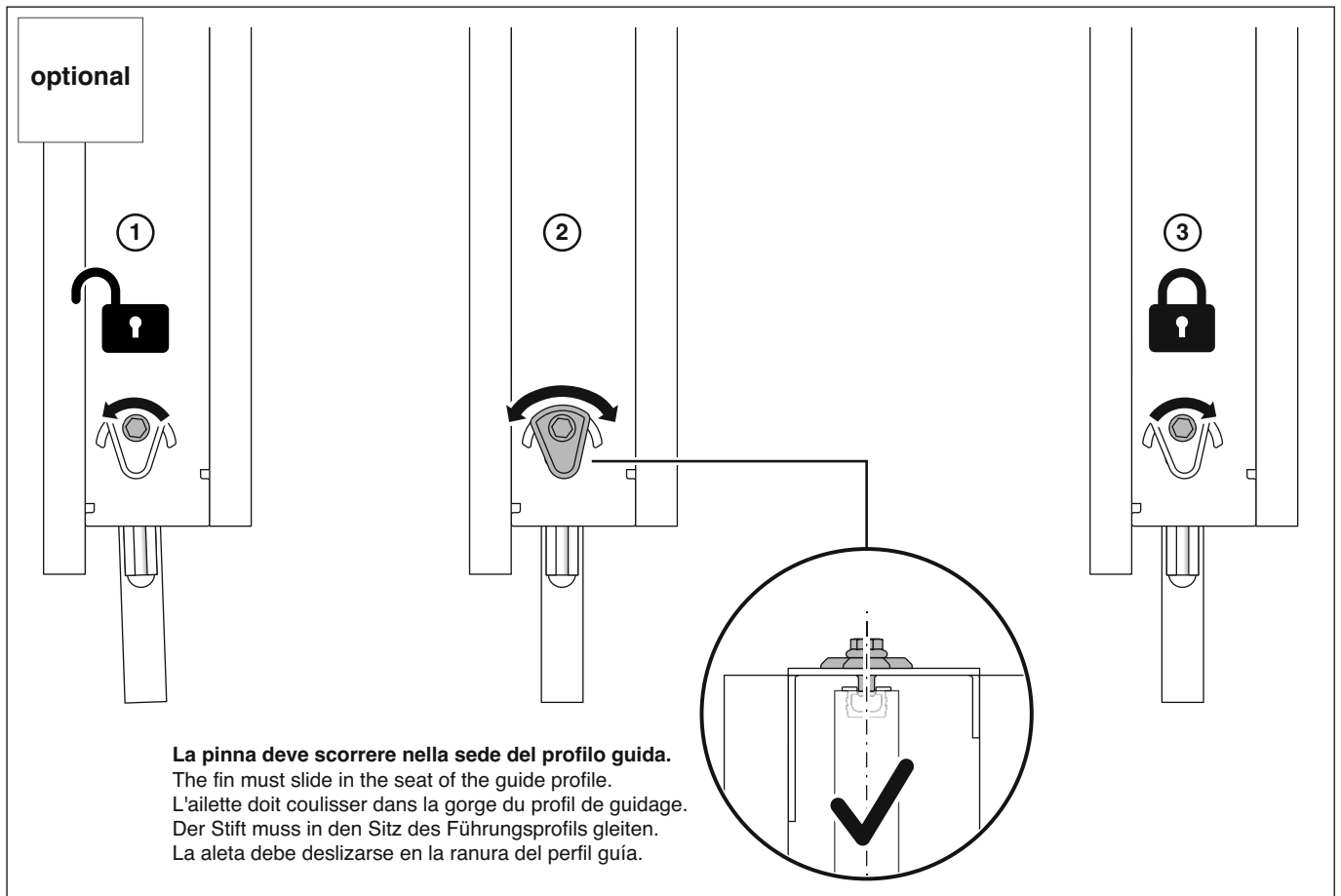

Bloccaggio dello stop finecorsa magnetico anteriore.

Lock of magnetic front end-stop.

Blocage du fin de course magnétique.

Befestigung des oberen Magnetanschlags.

Bloqueo del final de carrera magnético delantero.

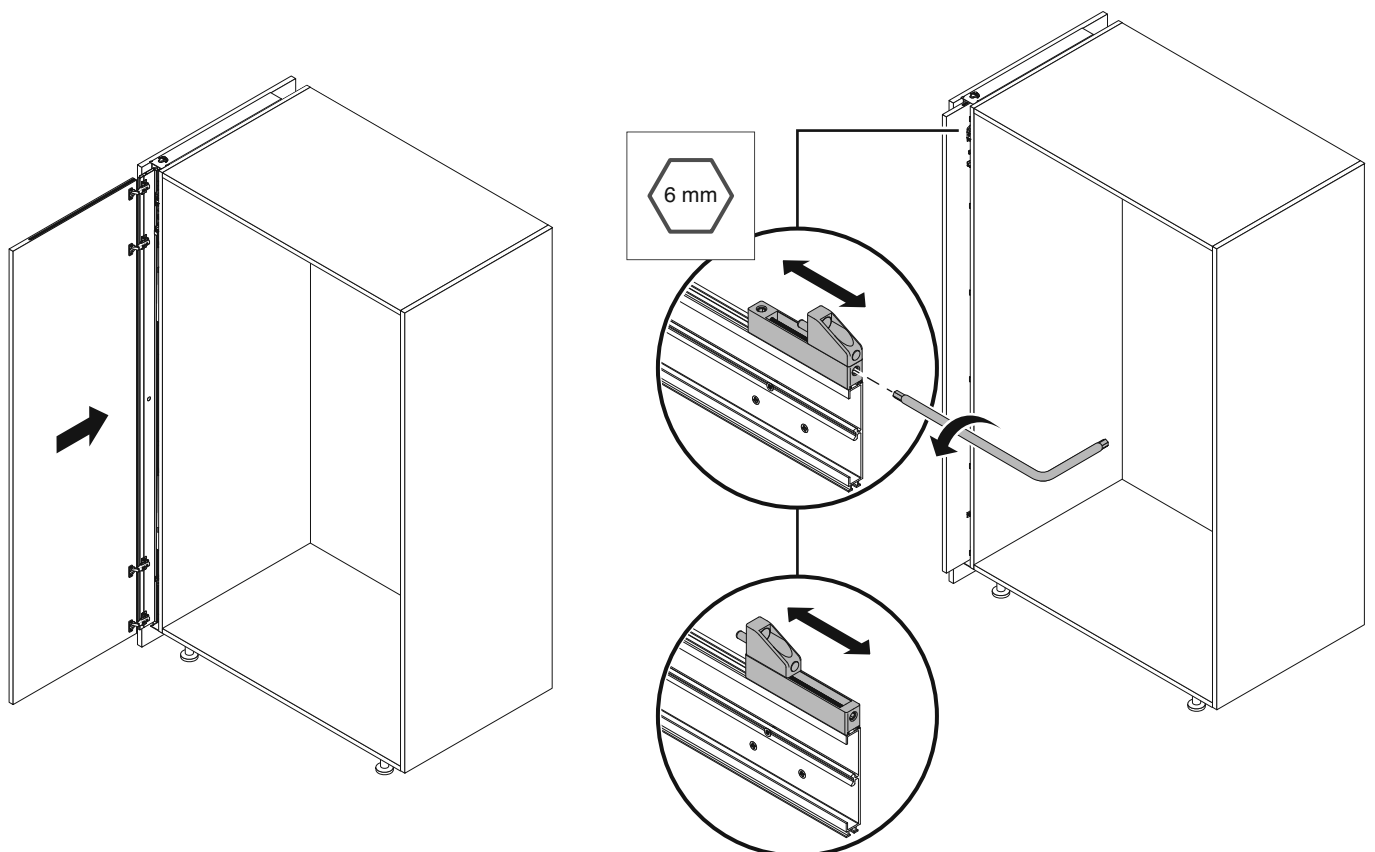

Montaggio del profilo cover frontale.

Mounting of the plastic front cover profile.

Montage du profil de finition.

Montage der Frontdichtung.

Montaje del perfil de cobertura frontal.

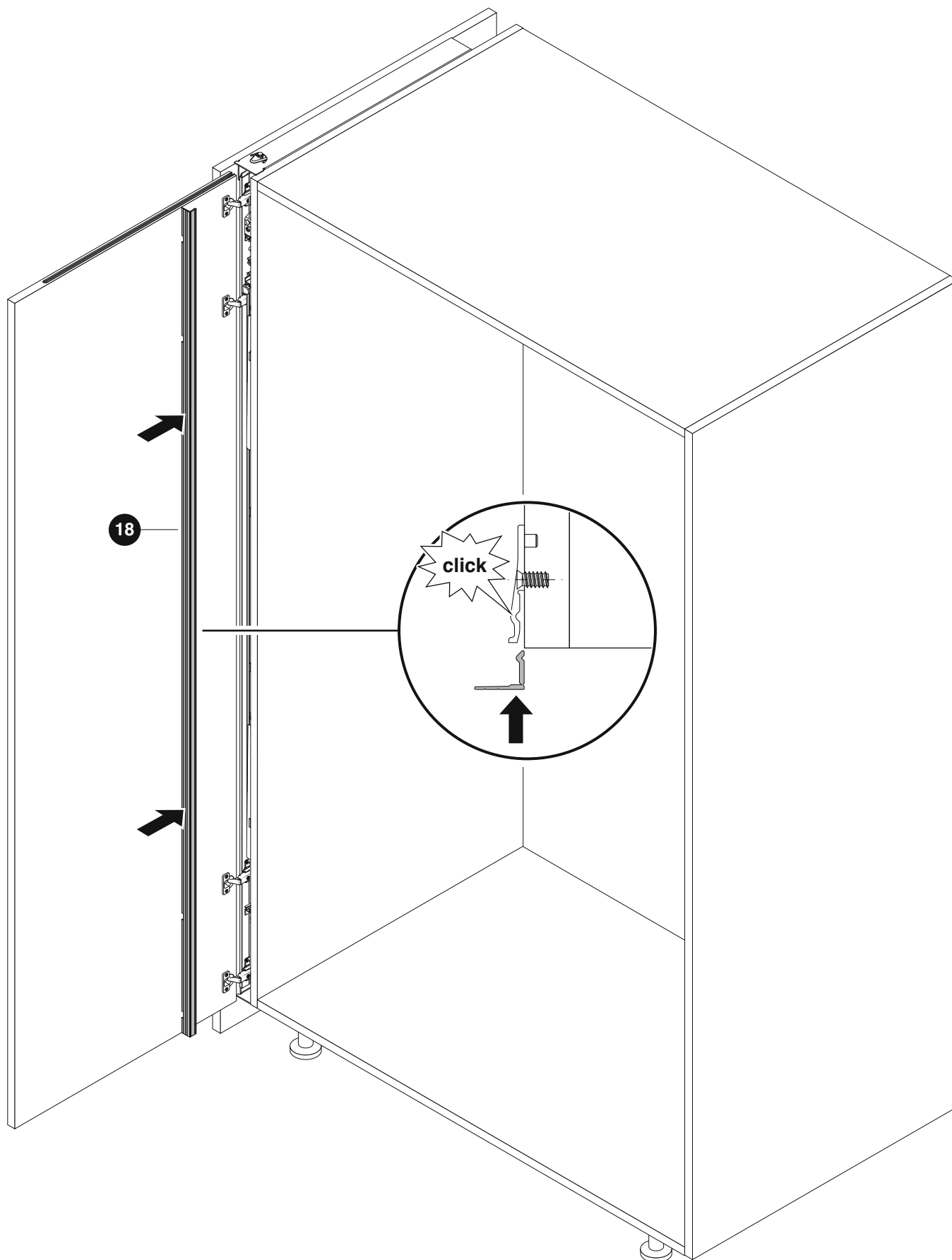



Cinetto F.lli S.r.l.

Via Meucci, 4
35030 Rubano (PD) Italy
Tel. +39 049 8977211
Fax +39 049 635822
www.cinetto.it
info@cinetto.it

